



**Addendum I to the DeKalb
County Department of Watershed
Management *Potable Water Main,
Gravity Sanitary Sewer, and Sanitary
Sewer Pump Station and Force Main
Design Standards Manual***

Purpose of Addendum

INTRODUCTION

The purpose of this addendum is to provide updated design criteria, construction requirements, standard details, and other pertinent information to the latest *Potable Water Main, Gravity Sanitary Sewer, and Sanitary Sewer Pump Station and Force Main Design Standards, Edition 2017, Version 0* (Design Standards Manual).

Project design shall follow the most current version of the Design Standards Manual and all subsequent addenda as posted on the Department of Watershed Management (DCDWM) website. Additional addenda, changes, revisions, additions, and/or corrections can be made by DCDWM at any time without prior notification.

All updated details in Appendix A, B, & C will retain the original detail number with a new revision date except for new details that have been added in this addendum. All references to details in the body of the Design Manual shall be to the latest version either found in this addendum or subsequent addenda.

EFFECTIVE DATE

This addendum to the DCDWM Design Standards Manual, Edition 2017, Version 0 will become effective February 22, 2019.

All design and construction contracts advertised and all permits issued on or after February 22, 2019 will be governed by this addendum.

ADDENDUM ORGANIZATION

Deletions and Additions to Design Manual Section II:

Potable Water Main Design Standards.....Page 04

Deletions and Additions to Design Manual Section III:

Gravity Sanitary Sewer Standards.....Page 04

Deletions and Additions to Design Manual Appendix A:

Potable Water Main Design Standards.....Page 11

Deletions and Additions to Design Manual Appendix B:

Gravity Sanitary Sewer Standards.....Page 12

Deletions and Additions to Design Manual Appendix E:

General Construction StandardsPage 14

APPENDICES

Appendix A: New Potable Water Main Details

Appendix B: New Gravity Sanitary Sewer Details

Appendix C: New General Construction Details

1. Deletions and Additions to Design Manual Section II: Potable Water Main Design Standards

a) Page 27 – 4.1 Gate Valves, DELETE:

Gate valves shall only be used in sizes of two (2) inches through ten (10) inches. Greater than ten (10) inches may be permitted if using resilient seated gate valves. Gate valves shall be submitted to the **DCDWM** for approval prior to installation.

REPLACE WITH:

Gate valves shall be used for all sizes. Pipes greater than ten (10) inches shall use resilient seated gate valves and shall be submitted to **DCDWM** for approval prior to installation. Vaults shall be required at the discretion of DCDWM.

b) Page 28 – 4.2 Butterfly Valves, DELETE:

Butterfly valves shall only be used in sizes sixteen (16) inches and larger.

REPLACE WITH:

Butterfly valves shall not be used except as deemed necessary by the design engineer and approved by DCDWM and only for sizes sixteen (16) inches and larger.

2. Deletions and Additions to Design Manual Section III: Gravity Sanitary Sewer Standards

a) Page 45 – 3. Depth of Pipe Burial, DELETE:

The minimum depth of cover over a sanitary sewer line within the road right-of-way shall be seven (7) feet for PVC pipes. Maximum depth of cover over PVC pipes shall be fifteen (15) feet in paved and un-paved areas. Cover less than seven (7) feet within right-of-way requires the use of DIP and shall be approved only when site conditions dictate.

REPLACE WITH:

PVC pipes shall have a minimum depth of cover of four (4) feet and a maximum depth of cover of fifteen (15) feet in un-paved areas. DIP is the only pipe material allowed under the road right-of-way at any depth.

b) Page 51 – 3.a) Gravity Sanitary Sewer Lines, DELETE:

For pipe installed in flood plains, pipe joints shall be sealed on the outside using coal tar epoxy.

REPLACE WITH:

For pipe installed in flood plains, pipe joints shall be sealed on the outside using coal tar epoxy. DCDWM requires DIP installed in the 100-year flood plain unless a variance is approved.

c) Page 53 – 4.a Sewer Service Stubs, DELETE:

The minimum cover at finished grade for a sewer service shall be a minimum of four (4) feet at the end of stub.

REPLACE WITH:

The cover at finished grade for a sewer service shall be a maximum of three (3) feet at the end of stub.

d) Page 55 – Table 3.6, DELETE:

Table 3.6 Manhole Sizing for Inside Drop Pipe Diameters		
MH Diameter (Feet)	Inside Drop	Outside Drop
5	≤ 16 inches	OK
*6	≤ 24 inches	OK
*7	≤ 36 inches	OK
*8	≤ 48 inches	OK

REPLACE WITH:

Table 3.6 Manhole Sizing for Inside Drop Pipe Diameters	
MH Diameter (Feet)	Inside Drop
5	≤ 16 inches
*6	≤ 24 inches
*7	≤ 36 inches
*8	≤ 48 inches

e) Page 55 – E.1.a) Diameter: Manhole *DELETE*:

Manholes with more than one (1) drop pipe (inside or outside) shall be submitted for review and the size of the manhole shall be at the discretion of the County.

REPLACE WITH:

Manholes with more than one (1) drop pipe (inside) shall be submitted for review and the size of the manhole shall be at the discretion of the County.

f) Page 55 – E.1.b) Drop Connection, *DELETE*:

An inside or outside drop connection, or pipe, shall be provided for any size sanitary sewer line entering a manhole at an elevation of more than two (2) feet above the manhole invert. Drop connections shall be avoided for new gravity sanitary sewer systems; however, they may be unavoidable when connecting to existing structures (see Construction Details S-003 and S-027 in **Appendix B**).

Manholes with drop connection pipes shall be indicated on the construction plans, profile section. The County shall determine whether an inside or outside drop shall be approved and the size of manhole to be installed.

The outside drop pipe shall be constructed of ductile iron materials.

All outside ninety- (90-) degree elbows shall have thrust block poured below the elbow.

Inside drops shall be permitted on a case-by-case basis as approved by the **County**.

REPLACE WITH:

An inside drop connection, or pipe, shall be provided for any size sanitary sewer line entering a manhole at an elevation of more than two (2) feet above the manhole invert.

Drop connections shall be avoided for new gravity sanitary sewer systems; however, they may be unavoidable when connecting to existing structures (see Construction Details S-003 and S-027 in **Appendix B**).

Manholes with drop connection pipes shall be indicated on the construction plans, profile section. The County shall determine whether an inside drop shall be approved and the size of manhole to be installed.

The inside drop pipe shall be constructed of schedule 80 PVC materials.

Outside drops shall be permitted on a case-by-case basis as approved by the **County**.

All outside ninety- (90-) degree elbows shall have thrust block poured below the elbow.

g) Page 56 – E.1.c) Doghouse Manholes, DELETE:

Doghouse manholes are to be utilized for connection to existing twelve- (12-) inch or larger sanitary sewer lines and may be authorized by the DCDWM Inspector on eight- (8-) and ten- (10) inch lines for existing high flow conditions. See Construction Detail S-026 in **Appendix B**. No bypass pumping shall be paid by the County when doghouse manholes are installed.

REPLACE WITH:

Doghouse manholes are to be utilized for connection to existing twelve- (12-) inch or larger sanitary sewer lines and may be authorized by the DCDWM Inspector on eight- (8-) and ten- (10-) inch lines for existing high flow conditions. See Construction Detail S-026 in **Appendix B**.

h) Page 58 – E.2.c) Manhole Cone, DELETE:

Manhole cones shall be eccentric and precast concrete. The top elevation on any manhole greater than three (3) feet above the finished grade shall have a flat top precast concrete with a bolt down type ERGO casting or equal. The top elevation of manhole frames shall be adjusted to grade in areas such as streets, alleys, and parking lots or where indicated on the plans. A maximum adjustment of up to twelve (12) inches shall be allowed. Precast concrete adjusting rings may be used with the approval of the **County**.

Adjustments greater than twelve (12) inches shall be made by changing precast riser sections.

The top of the wall of the manholes shall be leveled off with mortar so as to form a flat surface upon which the manhole frame is to rest.

REPLACE WITH:

Manhole cones shall be concentric and precast concrete. The top elevation on any manhole greater than three (3) feet above the finished grade shall have a flat top precast concrete with a bolt down type ERGO casting or equal. The top elevation of manhole frames shall be adjusted to grade in areas such as streets, alleys, and parking lots or where indicated on the plans. A maximum adjustment of up to twelve (12) inches shall be allowed. Precast concrete adjusting rings may be used with the approval of the **County**.

Adjustments greater than twelve (12) inches shall be made by changing precast riser sections.

The top of the wall of the manholes shall be leveled off with mortar so as to form a flat surface upon which the manhole frame is to rest.

i) Page 61 – E.2.h) Steps, DELETE:

Prior to the **Contractor** ordering any manholes, the **Contractor** shall receive approval from **DCDWM** regarding the installation of steps within the manhole.

Manhole steps shall meet the latest revision of ASTM C478 and shall conform to the requirements of the Occupational Safety and Health Standards, U.S. Department of Labor. Steps shall be equal to M.A. Industries, Inc. Model (PS-1) or (PS-1 PF). The **Contractor** shall ensure that steps are installed securely and able to bear design loads.

The uppermost step shall be cast into the side of the manhole no greater than eighteen (18) inches below the top of manhole cover. The steps shall be continued in alignment downward along the interior vertical side of the manhole to a point no lower than the crown of the largest sanitary sewer. Spacing of steps shall not exceed twelve (12) vertical inches. Steps shall not descend over any pipe connection into the manhole. Step dimensioning and spacing are presented in Standard Details S-001 and S-006, **Appendix B**.

REPLACE WITH:

Manhole steps shall not be installed on new manholes of any size or in any location.

j) Page 61 – E.2.i) Frames and Covers, DELETE:

Manhole frames and covers within paved areas shall meet the latest revision of ASTM A48, Class 30 or ASTM 536. Covers are to be solid with exception of pick hole(s) located at the

cover's circumference, not protruding through the cover. Cast iron frames and covers shall be matched for proper fit. The cast iron frame for the manhole cover shall be set at the required elevation and properly anchored to the precast manhole. Refer to Standard Details S-007 and S-009 in **Appendix B** for manhole frame and cover requirements in paved areas. With **DWM's** approval, the **Contractor** may use an ERGO type ring and cover. Approved manufacturers are ERGO by EJ - americas.ejco.com/hinged-manhole-cover, or approved equal. Composite MH frames and covers (bolt down and capable of H2O loading), **ATG – Aqua Technology Group or approved equal. www.Aquatechnologygroug.com**, shall only be used with the approval of **DCDWM**.

During the design phase **DCDWM** will determine if chimney seals will be required. Where there is evidence of leakage in existing manhole chimneys, chimney seals may be used with **DCDWM** approval.

Where manholes are constructed in non-paved areas, the top surface of the frame and cover shall have bolt-down lids with a watertight gasket. Locked manhole covers may be desirable in isolated easement locations or where vandalism may be a problem. Manholes in wooded or un-maintained easement areas shall be a minimum of twenty-four (24) inches above ground level and a minimum of two (2) feet above the one hundred- (100-) year flood plain; whichever is greater. Manholes located within the one hundred- (100-) year flood plain shall contain manhole frames that are bolted to the eccentric cone in order to stabilize the manhole adjustment rings. In these cases, the manhole adjustment rings shall contain pre-drilled holes for the bolts from the pre-cast manufacturer. Manhole concrete rings shall be secured to each other. This is essential in flood plain areas where the slide and tilt of precast rings is likely to occur due to buoyancy. Provide anti-flotation collars in flood plain locations. If the manhole top elevation is to be three (3) feet or higher above grade a flat top manhole shall be required to allow for safe and easy access. Height above grade for manholes on sloped ground in un-maintained areas shall be measured on the uphill side of the manhole. Manholes in maintained grass areas may be flush with the ground. Refer to Standard Detail S-008 in **Appendix B** for manhole frame and cover requirements in non-paved areas.

Top of cover shall be factory imprinted to read "**DeKalb Sewer.**"

The frames shall be properly set in place in a full bed of mortar and adjusted so as to make the top of the frame conform to the finished surfaces when located in streets, public highways and paved areas. In other locations, they shall conform to such elevations as are required. All frames and covers are to be set so as to provide access to the manhole.

REPLACE WITH:

Manhole frames and covers within paved areas shall meet the latest revision of ASTM A48, Class 35B. Covers are to be solid with exception of pick hole(s) located at the cover's circumference, not protruding through the cover. Cast iron frames and covers shall be matched for proper fit. The cast iron frame for the manhole cover shall be set at the required elevation and properly anchored to the precast manhole. Refer to Standard Details S-008 and S-009 in **Appendix B** for manhole frame and cover requirements in paved areas. With **DWM's** approval, the **Contractor** may use an ERGO type ring and cover. Approved manufacturers are ERGO by EJ - americas.ejco.com/hinged-manhole-cover, or approved equal. Composite MH frames and covers (bolt down and capable of H20 loading), **ATG –**

Aqua Technology Group or approved equal. www.Aquatechnologygroug.com, shall only be used with the approval of **DCDWM**.

During the design phase **DCDWM** will determine if chimney seals will be required. Where there is evidence of leakage in existing manhole chimneys, chimney seals may be used with **DCDWM** approval.

Where manholes are constructed in non-paved areas, the top surface of the frame and cover shall have bolt-down lids with a watertight gasket. Locked manhole covers may be desirable in isolated easement locations or where vandalism may be a problem. Manholes in wooded or un-maintained easement areas shall be a minimum of twenty-four (24) inches above ground level and a minimum of two (2) feet above the one hundred- (100-) year flood plain with a maximum height of four (4) feet above grade. Manholes located within the one hundred- (100-) year flood plain shall contain manhole frames that are bolted to the concentric cone in order to stabilize the manhole adjustment rings. In these cases, the manhole adjustment rings shall contain pre-drilled holes for the bolts from the pre-cast manufacturer. Manhole concrete rings shall be secured to each other. This is essential in flood plain areas where the slide and tilt of precast rings is likely to occur due to buoyancy. Provide anti-flotation collars in flood plain locations. If the manhole top elevation is to be three (3) feet or higher above grade a flat top manhole shall be required to allow for safe and easy access. Height above grade for manholes on sloped ground in un-maintained areas shall be measured on the uphill side of the manhole. Manholes in maintained grass areas may be flush with the ground. Refer to Standard Detail S-008 in **Appendix B** for manhole frame and cover requirements in non-paved areas.

Top of cover shall be factory imprinted to read "**Property of DeKalb County Sewer**" as shown in Detail S-008.

The frames shall be properly set in place in a full bed of mortar and adjusted so as to make the top of the frame conform to the finished surfaces when located in streets, public highways and paved areas. In other locations, they shall conform to such elevations as are required. All frames and covers are to be set so as to provide access to the manhole.

k) Page 63 – E.3 Backfilling Trenches, DELETE:

No clay backfill shall be used in pipe trenches under roadways or other paved areas. In such paved areas where clay is encountered, trenches shall be backfilled with crushed rock compacted to a density of not less than ninety-five percent (95%) of the maximum dry density as determined by the standard proctor test ASTM D698 (latest version).

REPLACE WITH:

Pipe trenches under roadways shall be backfilled with crushed rock compacted to a density of not less than ninety-five percent (95%) of the maximum dry density as determined by the standard proctor test ASTM D698 (latest version).

3. Deletions and Additions to Design Manual Appendix A: Potable Water Main Design Standards

a) Standard Details List – Potable Water, ADD:

STANDARD DETAILS LIST – Potable Water	
Detail Number	Title
W-028	Backflow Prevention Atmospheric Vacuum Breaker (AVB)
W-029	Backflow Prevention Pressure Vacuum Breaker Assembly (PVB) Installation

b) Detail W-007, Typical Gate Valve Installation (09/2017), DELETE:

REPLACE WITH:

Detail W-007, Typical Gate Valve Installation (02/2019)

c) Detail W-026, Butterfly Valve and Vault Assembly No. 1 (09/2017), DELETE:

REPLACE WITH:

Detail W-026, Butterfly Valve and Vault Assembly No. 1 (02/2019)

- d) **Detail W-027, Butterfly Valve and Vault Assembly No. 2 (09/2017), DELETE:**

REPLACE WITH:

Detail W-027, Butterfly Valve and Vault Assembly No. 2 (02/2019)

- e) **INSERT: Detail W-028, Backflow Prevention Atmospheric Vacuum Breaker (AVB) (09/2017)**
- f) **INSERT: Detail W-029 Backflow Prevention Pressure Vacuum Breaker Assembly (PVB) Installation (09/2017)**

**NOTE: See Appendix A of this document for the new details*

4. Deletions and Additions to Design Manual Appendix B: Gravity Sanitary Sewer Standards

- a) **Standard Details List – Gravity Sanitary Sewer Delete Table, DELETE:**

Standard Details List – Gravity Sanitary Sewer	
Detail Number	Title
S -006	Typical Manhole Step
S-024	Large Diameter Manhole Base (Eccentric) Detail

- b) **Detail S-001, Standard Precast Manhole (09/2017), DELETE**

REPLACE WITH:

Detail S-001, Standard Precast Manhole (02/2019)

- c) **Detail S-002, Safety Platform Detail (09/2017), DELETE**

REPLACE WITH:

Detail S-002, Safety Platform Detail (02/2019)

- d) **Detail S-003, Outside Drop Connection for Precast Manhole (09/2017), DELETE**

REPLACE WITH:

Detail S-003, Outside Drop Connection for Precast Manhole (02/2019)

- e) **Detail S-005, Method of Manhole Abandonment (09/2017), DELETE**

REPLACE WITH:

Detail S-005, Method of Manhole Abandonment (02/2019)

- f) **Detail S-006, Typical Manhole Step (09/2017), DELETE**

- g) **Detail S-007, Concrete Collar for Manhole Frame and Cover (09/2017), DELETE**

REPLACE WITH:

Detail S-007, Concrete Collar for Manhole Frame and Cover (02/2019)

- h) **Detail S-008, Bolt Down Manhole Frame and Cover (09/2017), DELETE**

REPLACE WITH:

Detail S-008, Bolt Down Manhole Frame and Cover (02/2019)

- i) **Detail S-009, Traffic Manhole Frame and Cover (09/2017), DELETE**

REPLACE WITH:

Detail S-009 Traffic Manhole Frame and Cover (02/2019)

- j) **Detail S-012, Typical Service Line and Cleanout Detail (09/2017), DELETE**

REPLACE WITH:

Detail S-012 Typical Service Line and Cleanout Detail (02/2019)

- k) **Detail, S-014 Class “B” Bedding (09/2017), DELETE**

REPLACE WITH:

Detail S-014 Class “B” Bedding (02/2019)

- l) **Detail S-016, Alternate Deep Service Connection Detail (09/2017), DELETE**

REPLACE WITH:

Detail S-016 Alternate Deep Service Connection Detail (02/2019)

- m) **S-024, Large Diameter Manhole Base (Eccentric) Detail (09/2017), DELETE**

- n) **Detail S-025, Large Diameter Manhole Transition Base Detail (09/2017), DELETE**

REPLACE WITH:

Detail S-025 Large Diameter Manhole Transition Base Detail (02/2019)

- o) **Detail S-026, Manhole Over Existing Sewer (Doghouse) (09/2017), DELETE**

REPLACE WITH:

Detail S-026 Manhole Over Existing Sewer (Doghouse) (02/2019)

**NOTE: See Appendix B of this document for the new details*

5. Deletions and Additions to Design Manual Appendix E: General Construction Standards

- a) **Standard Details List – General Details, INSERT:**

Standard Details List – General Details	
Detail Number	Title
G-011	Concrete Encasement

b) Detail G-005, Typical Patch and Resurfacing Detail (09/2017), DELETE:

REPLACE WITH:

Detail G-005 Typical Patch and Resurfacing Detail (02/2019)

c) Detail G-006, Typical Asphalt Pavement Patch (09/2017), DELETE:

REPLACE WITH:

G-006 Typical Asphalt Pavement Patch (02/2019)

d) Detail G-008, Thrust Restraint (150 psi) Tie-rod Installation Detail (09/2017), DELETE:

REPLACE WITH:

G-008 Thrust Restraint (150 psi) Tie-rod Installation Detail (02/2019)

e) INSERT: Detail G-011 Concrete Encasement (11/2018)

**NOTE: See Appendix C of this document for the new details*

Appendix A: New Potable Water Main Details

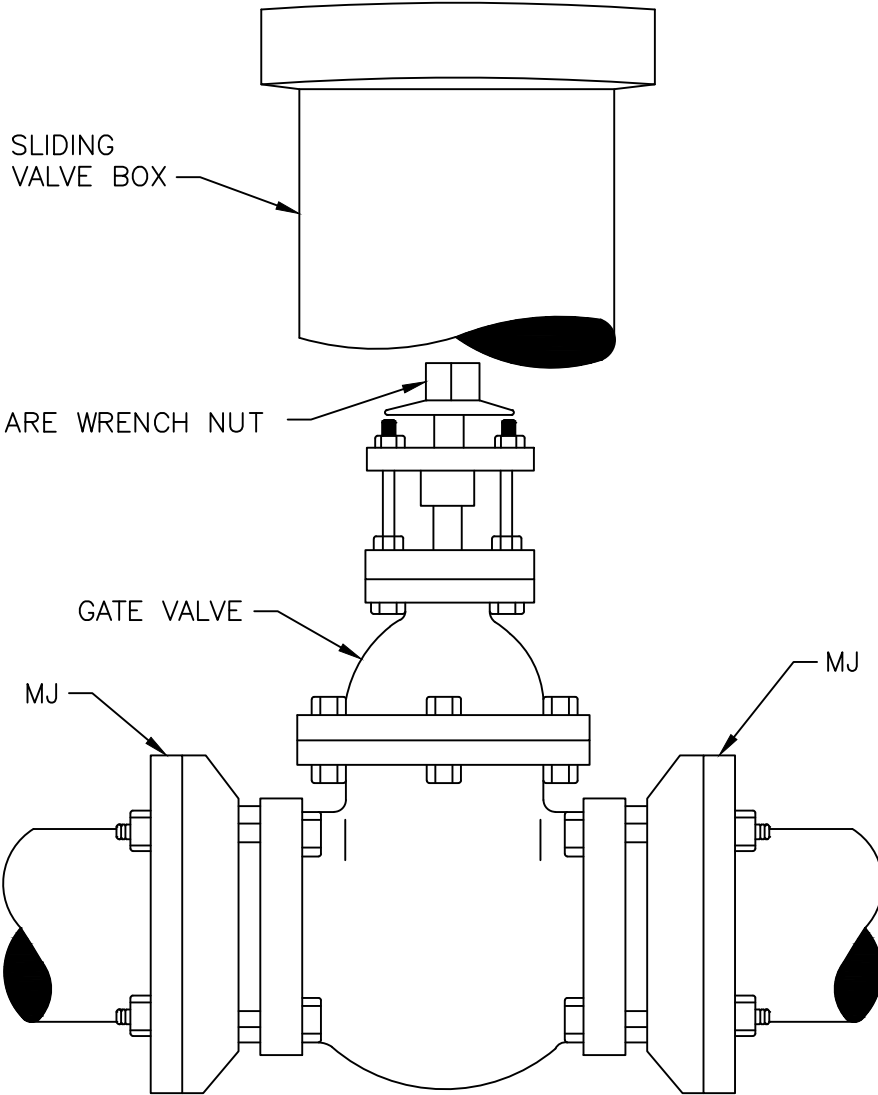

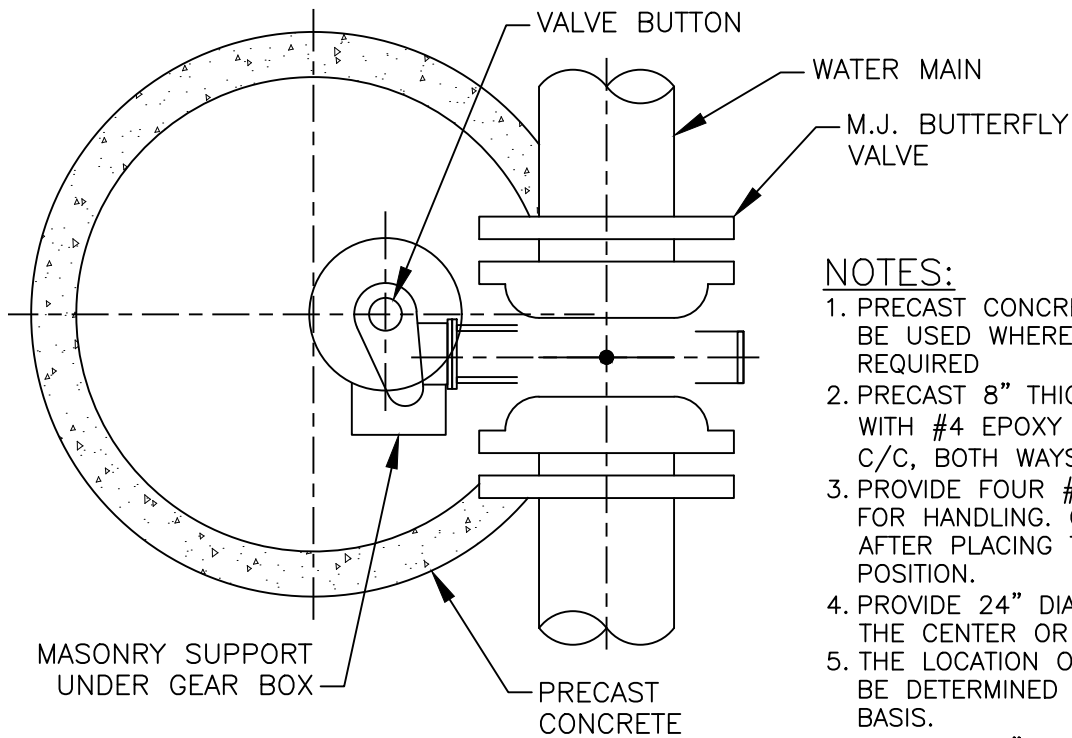

NOTES:

1. PRECAST CONCRETE TOP SLAB TO BE USED WHERE HEAD ROOM IS REQUIRED
2. PRECAST 8" THICK CONCRETE SLAB WITH #4 EPOXY COATED REBARS 4" C/C, BOTH WAYS.
3. PROVIDE FOUR #4 REBAR LUGS FOR HANDLING. CUT THE LUGS AFTER PLACING THE SLAB IN POSITION.
4. PROVIDE 24" DIAMETER OPENING IN THE CENTER OR AS REQUIRED.
5. THE LOCATION OF THE MANHOLE TO BE DETERMINED ON INDIVIDUAL BASIS.
6. PROVIDE 12" THICK #57 STONE.
7. BUTTERFLY VALVES SHALL ONLY BE USED IN SIZES SIXTEEN (16) INCHES AND LARGER.

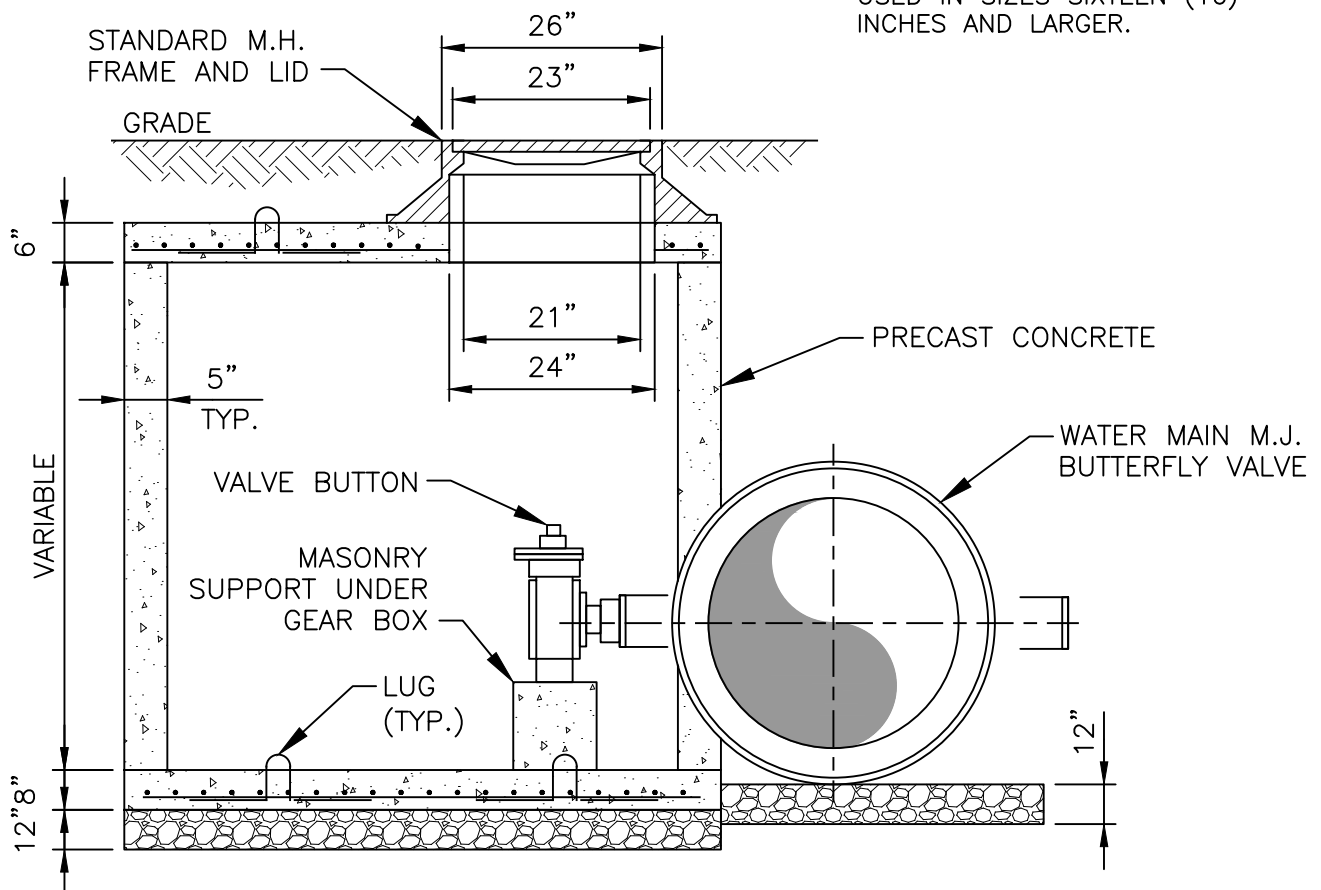

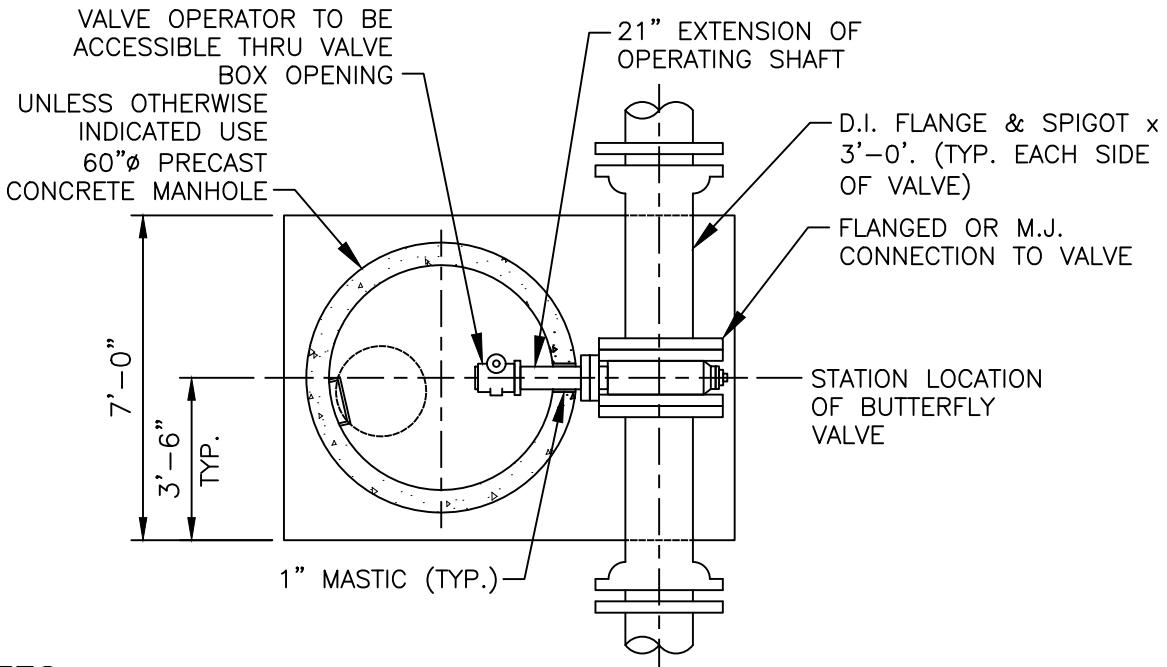

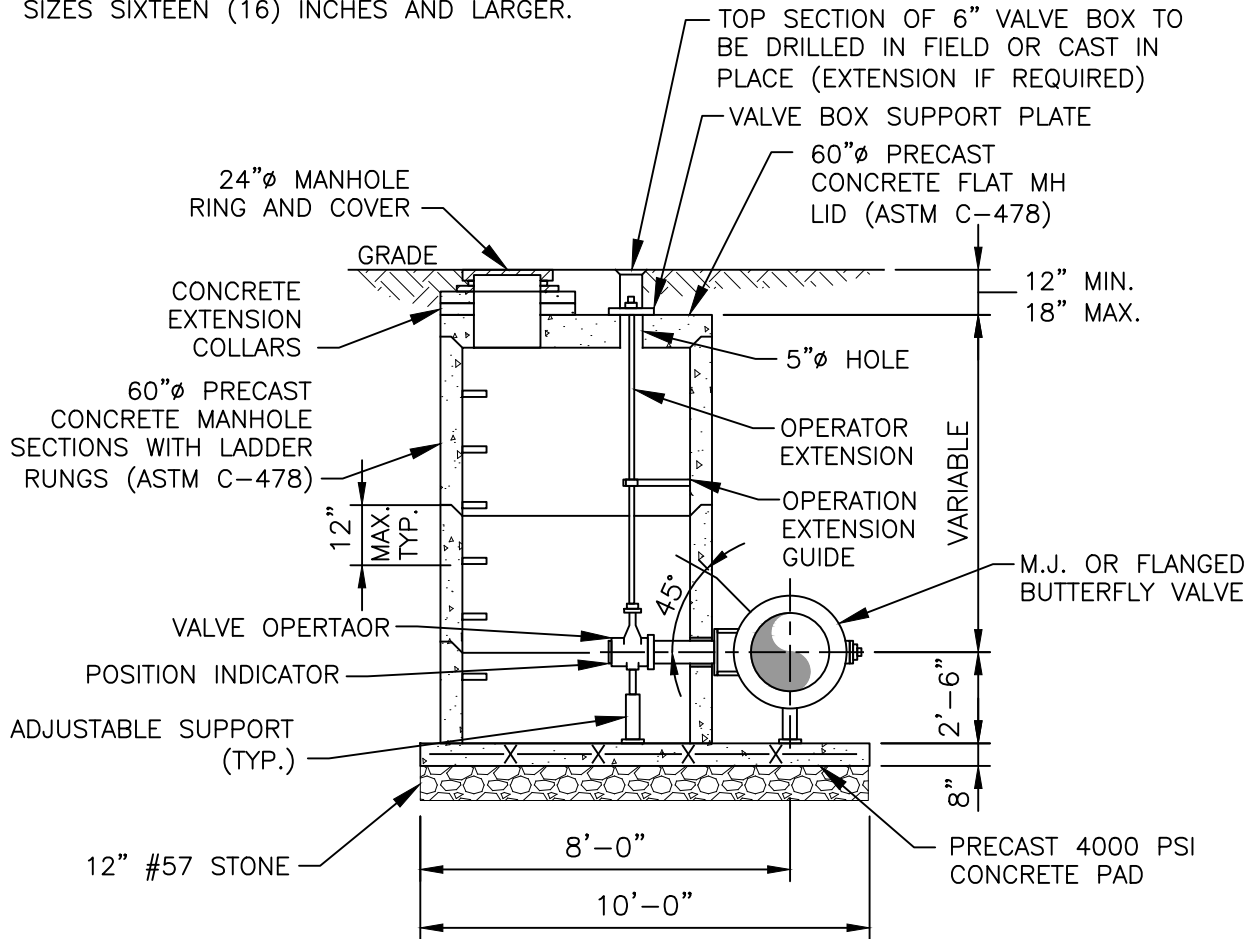

NOTES:

1. BUTTERFLY VALVES SHALL ONLY BE USED IN SIZES SIXTEEN (16) INCHES AND LARGER.



	STANDARD DETAILS	02/19
	Butterfly Valve And Vault Assembly No. 2 (Requires DCDWM Approval) NOT TO SCALE	
		DETAIL NO. W-027

SINGLE FAMILY RESIDENTIAL USE ONLY
ON IRRIGATION SYSTEMS

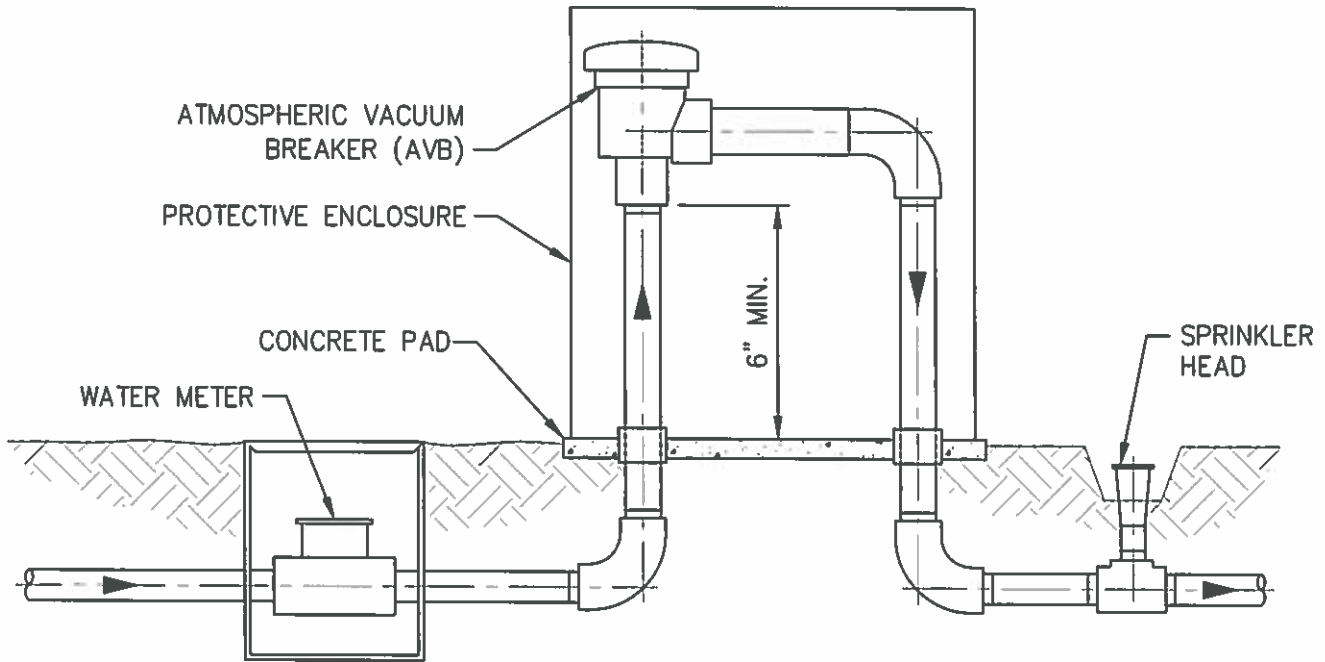

SPECIFICATIONS: THE CUSTOMER SHALL FURNISH AND INSTALL AN ATMOSPHERIC VACUUM BREAKER (AVB) IN A SIZE TO MATCH THAT OF THE REQUIRED SERVICE LINE CONNECTION. THE AVB BFP DEVICE SHALL CONTAIN AN AIR INLET VALVE, A CHECK SEAT AND AN AIR INLET PORT.

INSTALLATION INSTRUCTIONS: AVB IS ONLY ALLOWED FOR SINGLE FAMILY RESIDENCE USE ON AN IRRIGATION SYSTEM AN AVB MUST BE INSTALLED IN AN ORIENTATION DESIGNATED BY THE APPROVAL AGENCY RECOGNIZED BY DEKALB COUNTY DEPARTMENT OF WATERSHED MANAGEMENT. NO CONTROL VALVES SHALL BE INSTALLED DOWNSTREAM OF THE AVB DEVICE. AN AVB SHALL NOT BE INSTALLED WHERE IT IS SUBJECTED TO BACK PRESSURE. AN AVB SHALL NOT BE INSTALLED IN A PIT OR BELOW GRADE WHERE THE AIR INLET COULD BECOME SUBMERGED IN WATER OR WHERE FUMES COULD BE PRESENT AT THE AIR INLET.

AN AVB SHALL BE INSTALLED A MINIMUM OF 6 INCHES ABOVE THE HIGHEST POINT OF USE AND ANY DOWNSTREAM PIPING SUPPLIED FROM THE ASSEMBLY. AN AVB SHALL NOT BE SUBJECTED TO CONTINUAL USE AND SHALL NOT BE PRESSURIZED FOR MORE THAN 12 HOURS IN A 24 HOUR PERIOD.



AN ABOVE GROUND ENCLOSURE MUST BE PROVIDED FOR PROTECTION FROM FREEZING TEMPERATURES. AN AVB IS SUBJECT TO PERIODIC DISCHARGE AND COULD CAUSE WATER DAMAGE ESPECIALLY WHEN INSTALLED INSIDE. INSIDE INSTALLATION REQUIRES PRIOR APPROVAL FROM DEKALB COUNTY WATERSHED MANAGEMENT.

NOTE: A SIGNED BACKFLOW ASSEMBLY INSTALLATION AFFIDAVIT IS REQUIRED. NO CHEMICAL SYSTEMS MAY BE IN USE WITH IRRIGATION SYSTEM. PROPERTY OWNER SHALL PROVIDE AN ELEVATION SURVEY OF IRRIGATION SYSTEM.

INSPECTION: A PRE-INSTALLATION INSPECTION MUST BE SCHEDULED THROUGH DEKALB COUNTY DEPARTMENT OF WATERSHED MANAGEMENT. CONTACT BACKFLOW PREVENTION SECTION AT (404) 687-4075.

APPROVED ASSEMBLY'S (OR EQUIVALENT):

APOLLO	AVB1	1/2" - 2"
WATTS	188A	3/4" - 2"
WLKINS	710, 715	3/4" - 2"

	STANDARD DETAILS	09/17
	BACKFLOW PREVENTION ATMOSPHERIC VACUUM BREAKER (AVB)	
	Not To Scale	DETAIL NO. W-028

**SINGLE FAMILY RESIDENTIAL USE ONLY
ON IRRIGATION SYSTEMS**

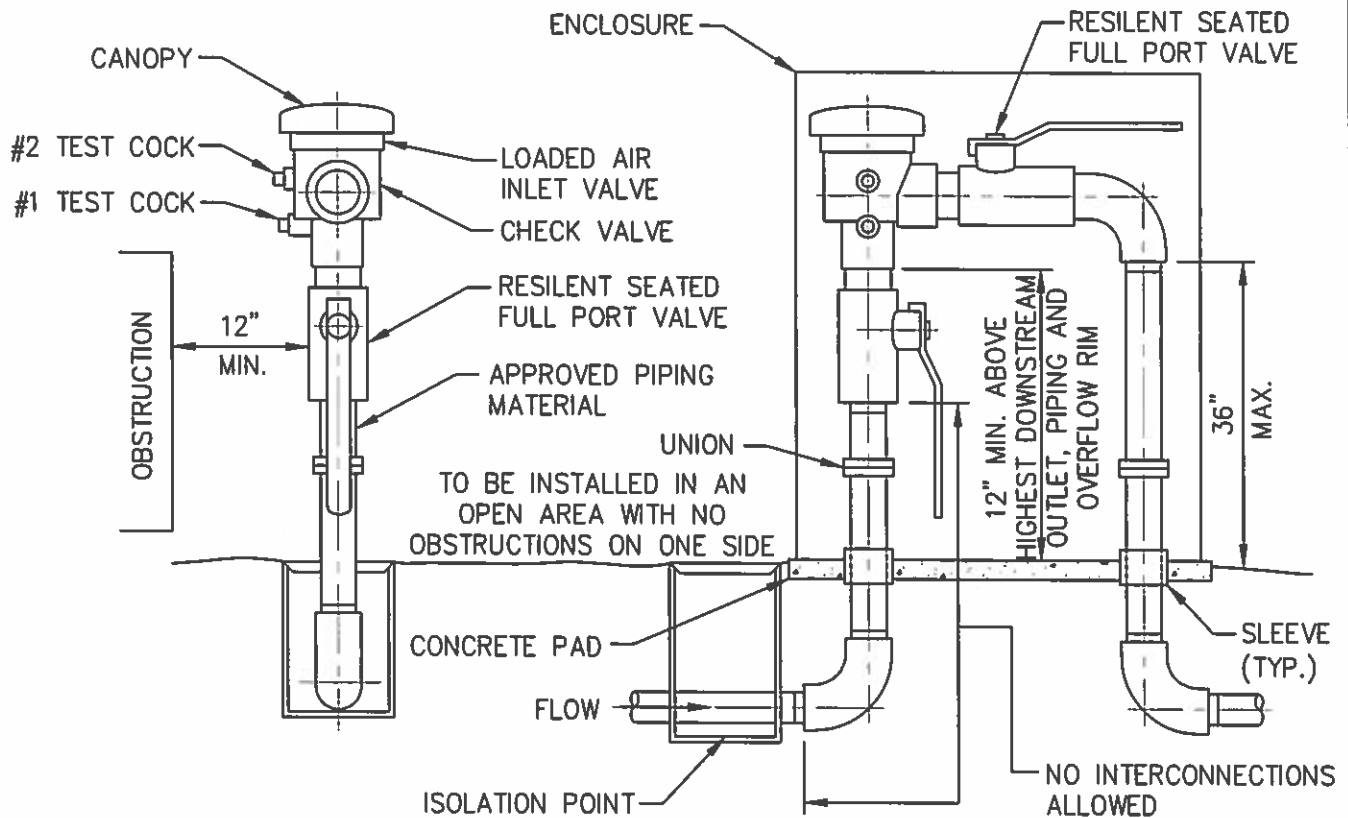

SPECIFICATIONS: THE CUSTOMER SHALL FURNISH AND INSTALL A PRESSURE VACUUM BREAKER (PVB) BACKFLOW PREVENTION ASSEMBLY (BFP) IN A SIZE TO MATCH THAT OF THE REQUIRED SERVICE LINE CONNECTION. THE PVB BFP ASSEMBLY SHALL BE PROVIDED WITH AN INDEPENDENTLY OPERATING INTERNALLY LOADED CHECK VALVE AND AN INDEPENDENTLY OPERATING LOADED AIR INLET VALVE LOCATED ON THE DISCHARGE SIDE OF THE CHECK VALVE. THE ASSEMBLY IS TO BE EQUIPPED WITH PROPERLY LOCATED RESILIENT SEATED TEST COCKS AND TIGHTLY CLOSING RESILIENT SEATED SHUTOFF VALVES ATTACHED AT EACH END OF THE ASSEMBLY.

NOTE: ALL COMPONENTS OF THE ASSEMBLY SHALL BE CERTIFIED BY A NATIONALLY RECOGNIZED TESTING LABORATORY, THE PVB BFP ASSEMBLY SHALL HAVE APPROVAL AND CONFORM TO ALL CURRENT REQUIREMENTS OF THE UNIVERSITY OF SOUTHERN CALIFORNIA, FOUNDATION FOR CROSS-CONNECTION CONTROL AND HYDRAULIC RESEARCH (USC-FCCCHR). ASSEMBLY TO BE INDEPENDENTLY FACTORY TESTED AND SHIPPED AND INSTALLED AS A UNIT.

INSTALLATION INSTRUCTIONS: PVB IS ONLY ALLOWED FOR SINGLE FAMILY RESIDENCE USE ON AN IRRIGATION SYSTEM A PVB MUST BE INSTALLED IN THE ORIENTATION AS IT WAS APPROVED BY THE APPROVED AGENCY RECOGNIZED BY THE DEKALB COUNTY WATERSHED MANAGEMENT. A PVB SHALL NOT BE INSTALLED WHERE IT IS SUBJECTED TO BACK PRESSURE. A PVB SHALL NOT BE INSTALLED IN A PIT OR BELOW GRADE WHERE THE AIR INLET COULD BECOME SUBMERGED IN WATER OR WHERE FUMES COULD BE PRESENT AT THE AIR INLET. A PVB SHALL BE INSTALLED A MINIMUM OF 12 INCHES ABOVE THE HIGHEST POINT OF USE AND ANY DOWNSTREAM PIPING SUPPLIED FROM THE ASSEMBLY. AN ABOVE GROUND ENCLOSURE MUST BE PROVIDED FOR PROTECTION FROM FREEZING TEMPERATURES. A PVB IS SUBJECT TO PERIODIC DISCHARGE AND COULD CAUSE DAMAGE ESPECIALLY WHEN INSTALLED INSIDE. INSIDE INSTALLATION REQUIRES PRIOR APPROVAL FROM DEKALB COUNTY WATERSHED MANAGEMENT.

NOTE: A SIGNED BACKFLOW ASSEMBLY INSTALLATION AFFIDAVIT IS REQUIRED. NO CHEMICAL SYSTEMS MAY BE IN USE WITH IRRIGATION SYSTEM. PROPERTY OWNER SHALL PROVIDE AN ELEVATION SURVEY OF IRRIGATION SYSTEM.

ASSEMBLY TESTING: ALL PVB BFP'S SHALL BE TESTED AFTER INSTALLATION, REPAIR, RELOCATION, AND AT LEAST ANNUALLY THEREAFTER.

INSPECTION: A PRE-INSTALLATION INSPECTION MUST BE SCHEDULED THROUGH DEKALB COUNTY DEPARTMENT OF WATERSHED MANAGEMENT. CONTACT BACKFLOW PREVENTION SECTION AT (404) 687-4075.

APPROVED ASSEMBLY'S (OR EQUIVALENT):

FBCO	LF767FR	½", ¾", 1", 1 ¼", 1 ½", 2"
WATTS	LF800M4QT	½", ¾", 1", 1 ¼", 1 ½", 2"
WLKINS	720A	½", ¾", 1", 1 ¼", 1 ½", 2"



STANDARD DETAILS
**BACKFLOW PREVENTION
PRESSURE VACUUM BREAKER
ASSEMBLY (PVB) INSTALLATION**

Not To Scale

09/17



DETAIL NO. W-029

Appendix B: New Gravity Sanitary Sewer Details

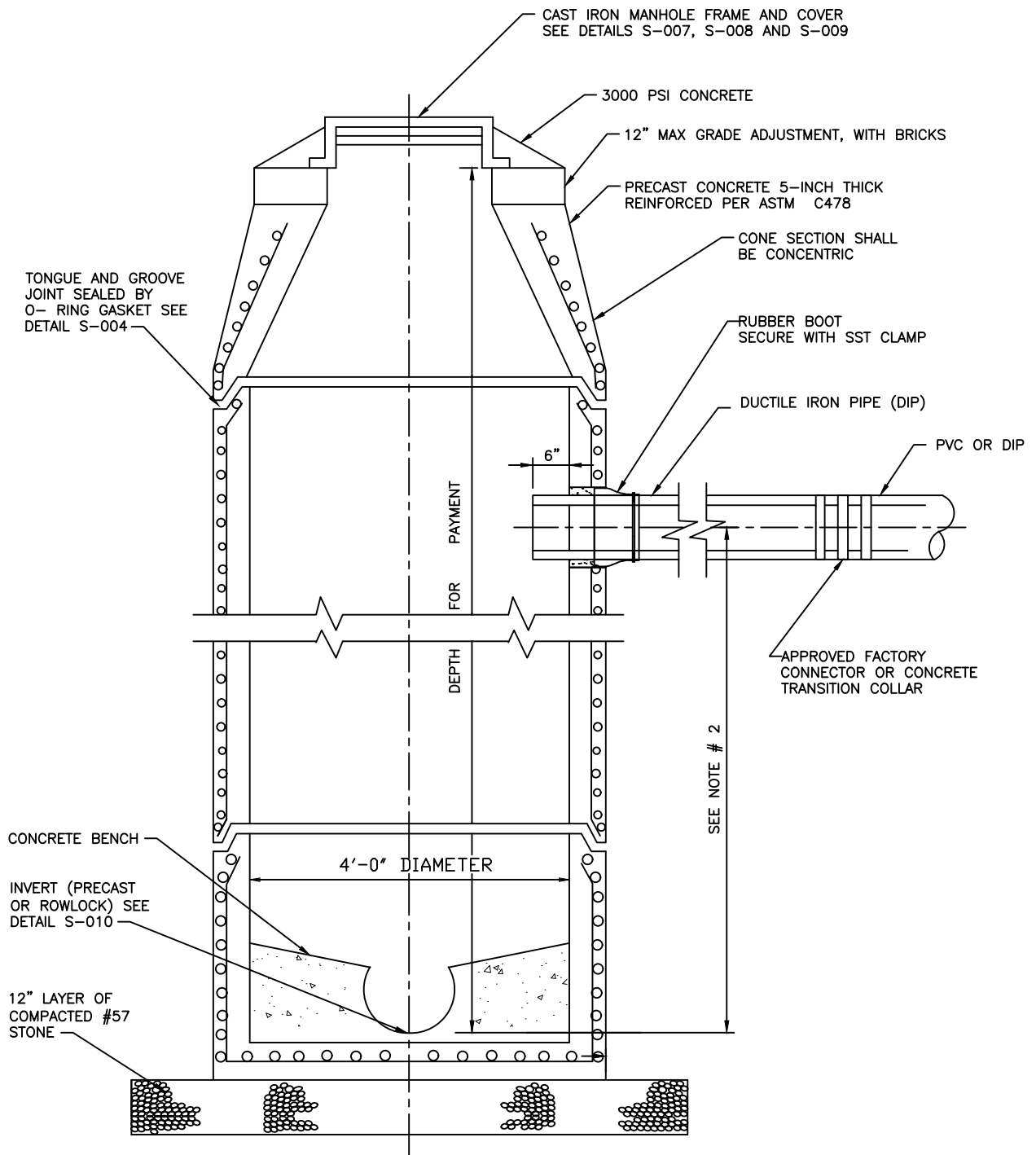

NOTES:

1. WHERE NECESSARY TO CONSTRUCT MANHOLE OVER EXISTING SEWER, 9" THICK CONCRETE POURED-IN-PLACE FOOTING/FOUNDATION MAY BE USED IN LIEU OF PRECAST BOTTOM SECTION.
2. WHERE DROP FROM INVERT OF MANHOLE TO INVERT OF INFLUENT PIPE(S) EXCEED 2'-0", AN INSIDE DROP CONNECTION SHALL BE REQUIRED EXCEPT WHEN DCDWM SPECIFICALLY APPROVES ITS ELIMINATION. SEE DETAILS S-003 OR S-027.
3. PRECAST ALL OPENINGS FOR PIPE IN BASE AND RISER UNITS.

STANDARD DETAILS

Standard Precast Manhole

NOT TO SCALE

02/19



DETAIL NO. S-001



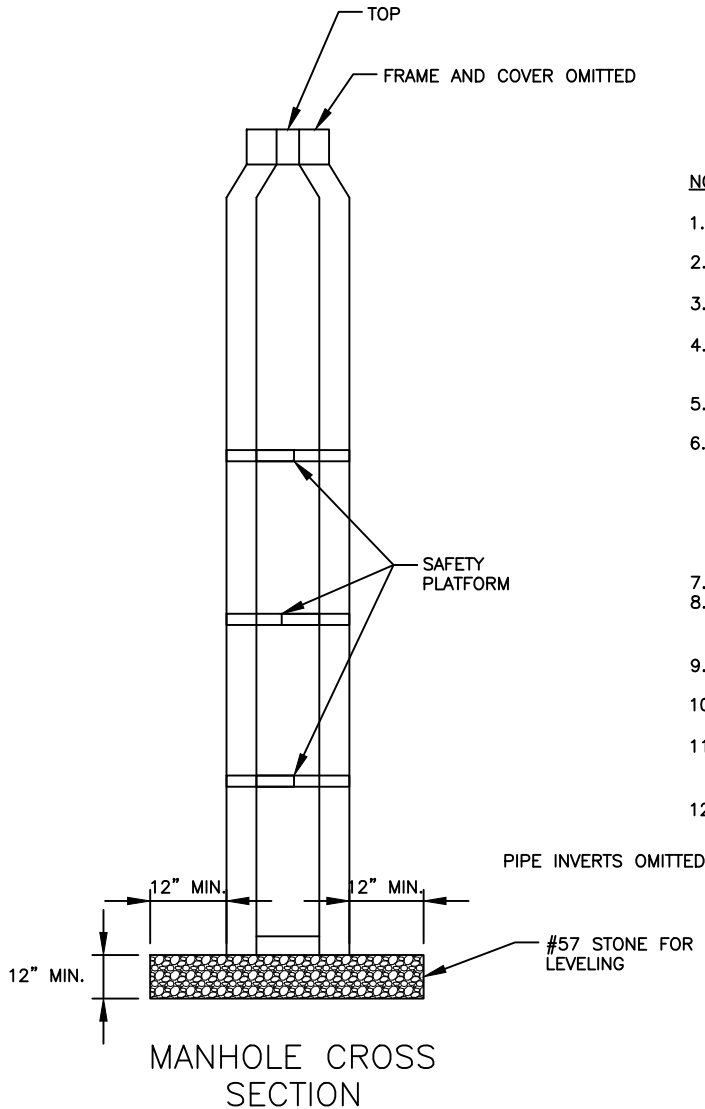

NOTES:

1. A DEEP MANHOLE IS CONSIDERED TO BE GREATER THAN 24'-0" IN DEPTH.
2. SAFETY PLATFORMS ARE REQUIRED ON ALL MANHOLES EQUAL TO OR GREATER THAN 16'-0" IN DEPTH.
3. SAFETY PLATFORMS ARE TO BE PLACED A MAX. DISTANCE OF 8'-0"-10'-0" APART.
4. PLATFORMS ARE TO BE DESIGNED TO OBTAIN A STRENGTH OF 4,000 PSI IN 28 DAYS. MANHOLE AND PLATFORM DESIGN SHALL CONFORM TO ASTM SPECS. C478, LATEST EDITION
5. REINFORCING STEEL HAS A MIN. YIELD STRENGTH OF 60,000 PSI.
6. SAFETY PLATFORM SLAB IS DESIGNED FOR A CONCENTRATED LOAD (P) AS FOLLOWS:

MANHOLE DIAMETER (FT)	P (LB)
4	12,000
5	10,000
6	8,000

7. SAFETY PLATFORM IS TO BE PLACED BETWEEN RISERS.
8. SAFETY PLATFORM IS TO BE PLACED AT MIDPOINT OF A MANHOLE OVER 20'-0" IN DEPTH. TWO PLATFORMS TO BE PLACED IN EQUAL DISTANCE AT A MANHOLE DEPTH OF 24'-0".
9. SAFETY PLATFORM IS TO BE PRECAST CONCRETE OR APPROVED EQUAL.
10. ALTERNATE OPENINGS IN SAFETY PLATFORMS AS INDIVIDUAL DESCENDS.
11. MANHOLES IN EXCESS OF 24'-0" IN DEPTH SHALL BE PRE-APPROVED BY PUBLIC WORKS AND HAVE SAFETY PLATFORMS WITH 8'-0"-10'-0" SPACING.
12. MANHOLES 20'-0" OR MORE IN DEPTH INCREASE TO 5'-0"Ø.

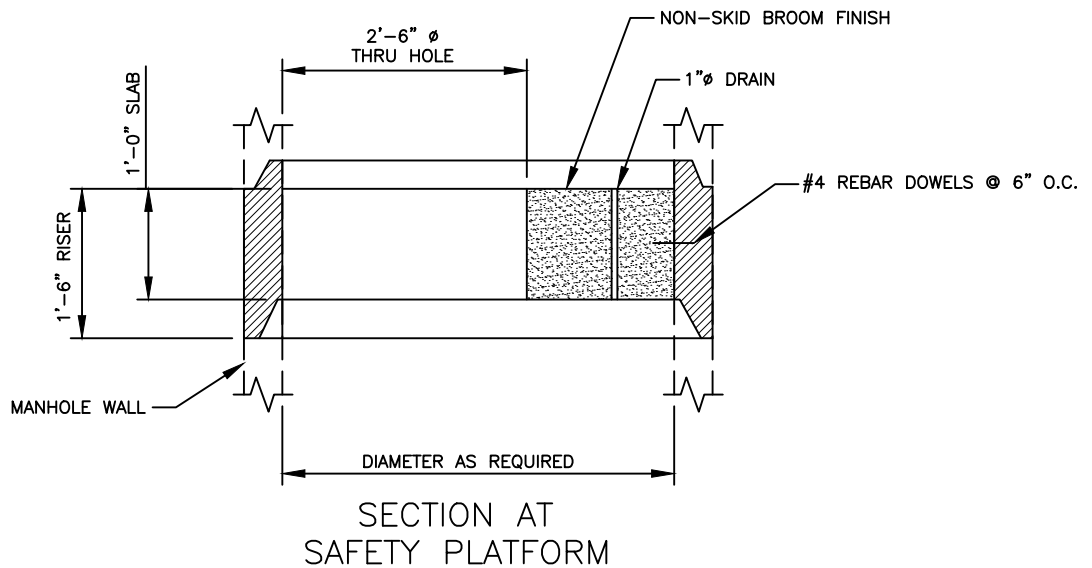

STANDARD DETAILS

Safety Platform Detail

NOT TO SCALE

02/19



DETAIL NO. S-002

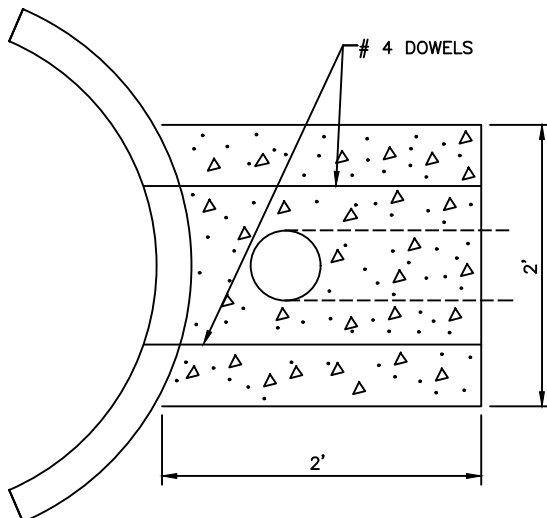
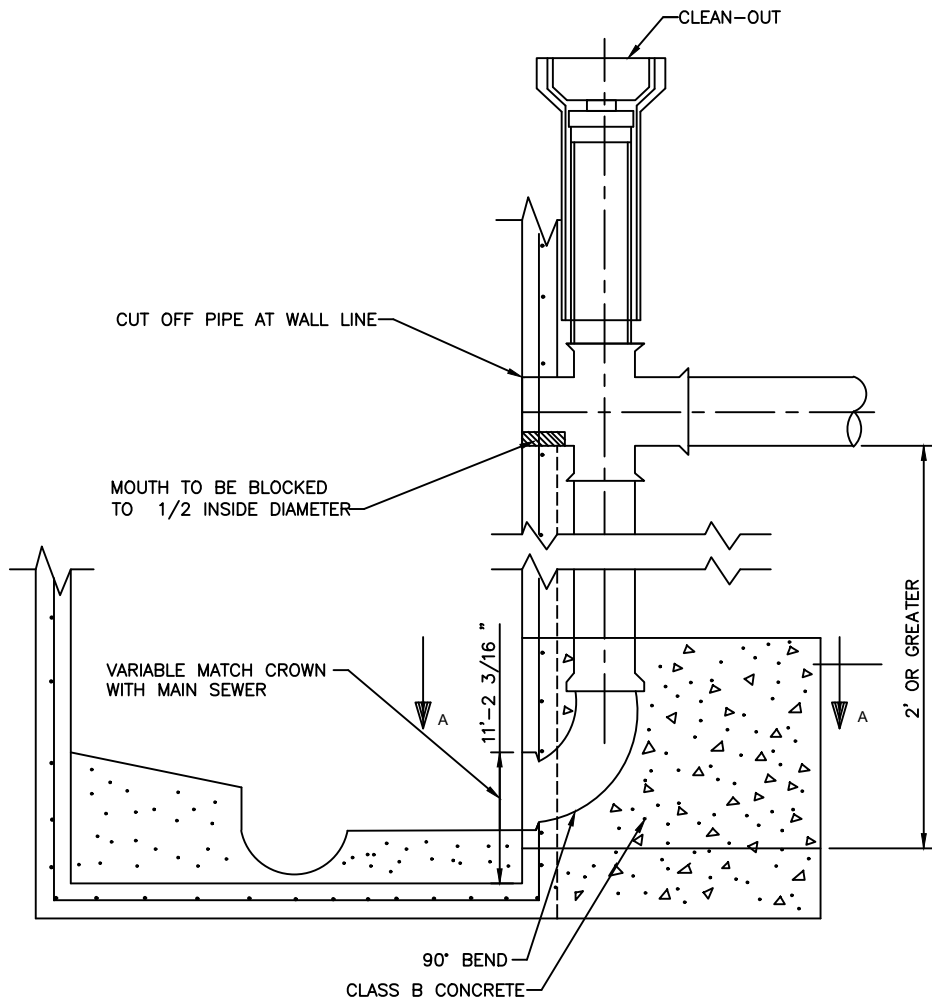

- NOTES:
1. "DROP CONNECTION" SHALL INCLUDE THE EXCAVATION, MH CORE, CONCRETE, DIP, FITTINGS AND OTHER INCIDENTALS NECESSARY TO COMPLETE THE ITEM. DUCTILE IRON PIPE (18' MIN) INSTALLED UPSTREAM OF THE TEE.
 2. ALL BENDS, TEES, AND FITTINGS REQUIRED TO INSTALL OUTSIDE DROP SHALL BE DUCTILE IRON.

	STANDARD DETAILS	02/19
	Outside Drop Connection For Precast Manhole (Requires DCDWM Approval) NOT TO SCALE	
		DETAIL NO. S-003

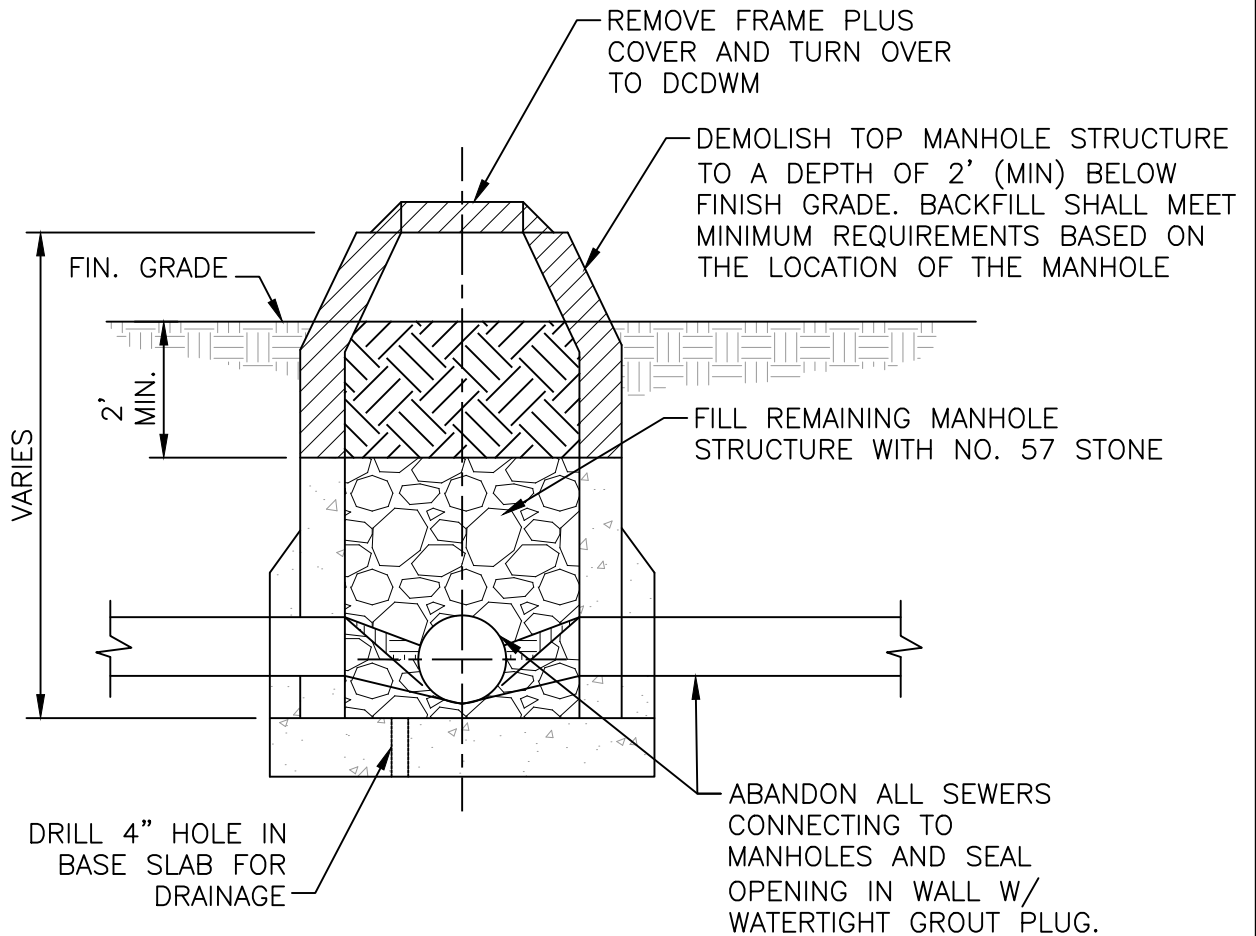

STANDARD DETAILS

Method of Manhole Abandonment

NOT TO SCALE

02/19



DETAIL NO. S-005



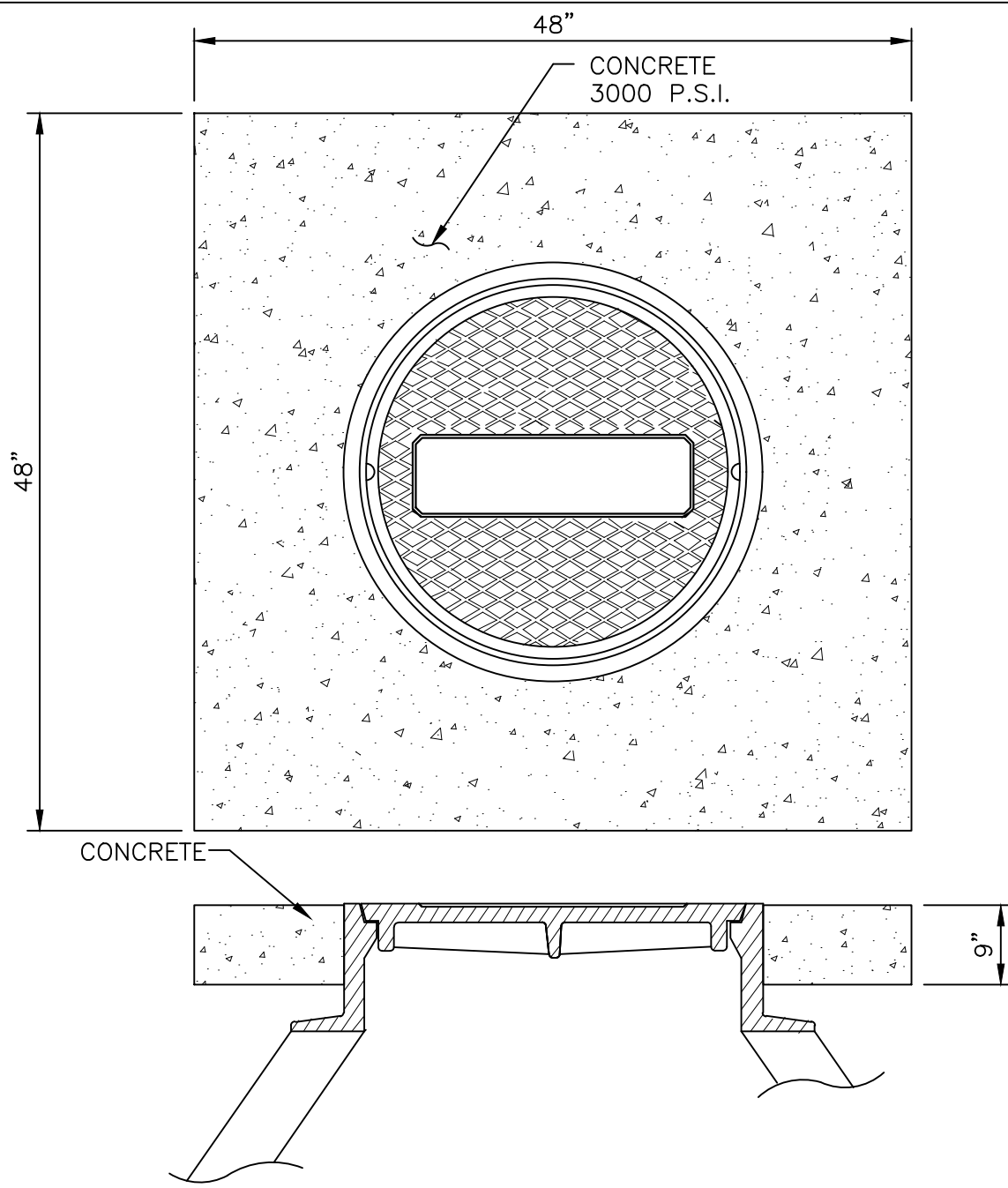

NOTE: CONCRETE COLLARS ONLY REQUIRED IN STREETS, ROADWAYS AND OTHER AREAS SUBJECT TO VEHICULAR TRAFFIC.



STANDARD DETAILS
 Concrete Collar for
 Manhole Frame and Cover

NOT TO SCALE

02/19



DETAIL NO. S-007

(4) 1/2"-13 HEX
HEAD STAINLESS STEEL
CAP SCREWS ON A
22 1/8"Ø BOLT CIRCLE

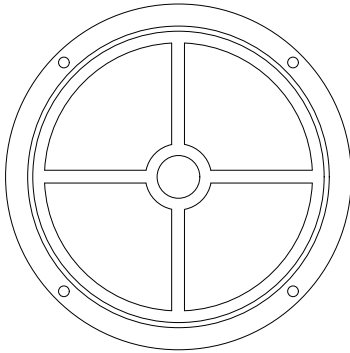

COVER BACK

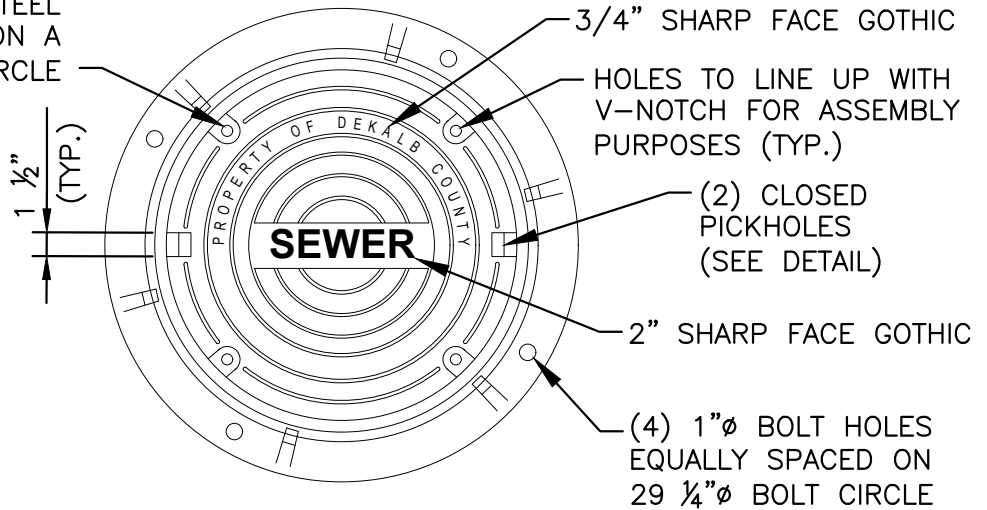

PLAN

DESIGN FEATURES

- MATERIALS:
 FRAME: GRAY IRON (CL35B)
 COVER: GRAY IRON (CL35B)
- DESIGN LOAD
 HEAVY DUTY
- COATING: UNDIPPED
- ✓ DESIGNATES MACHINED SURFACE

CERTIFICATION

- ASTM A48
- COUNTRY OF ORIGIN: USA

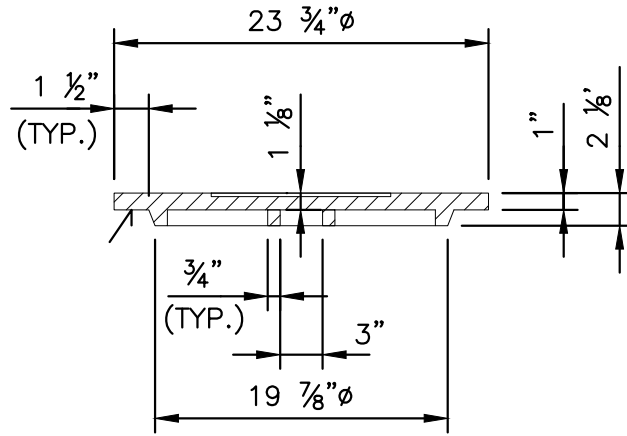

SECTION OF COVER

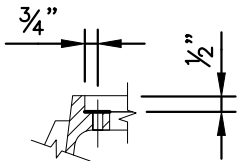

BOLTHOLE DETAIL

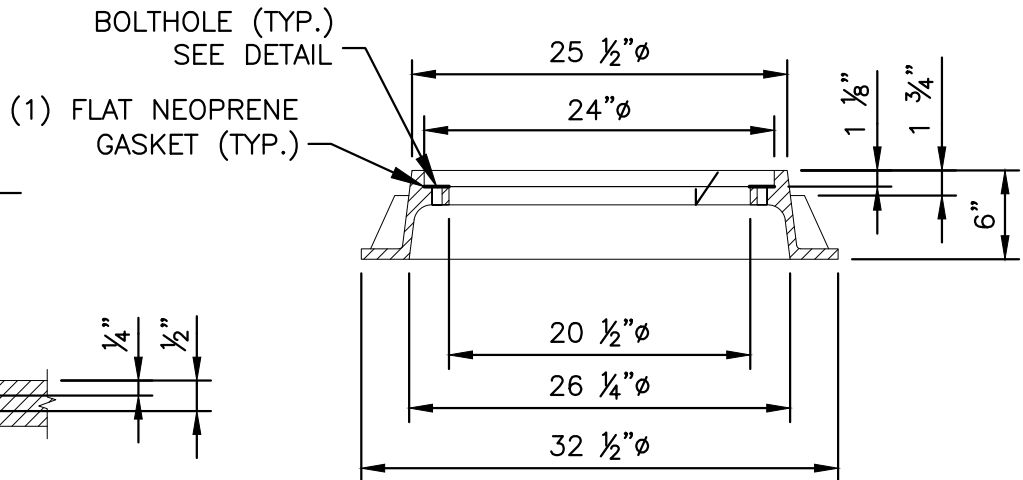

FRAME SECTION

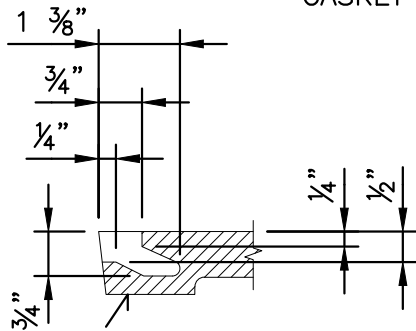

PICKHOLE DETAIL



STANDARD DETAILS

Bolt Down Manhole Frame and Cover

NOT TO SCALE

02/19



DETAIL NO. S-008

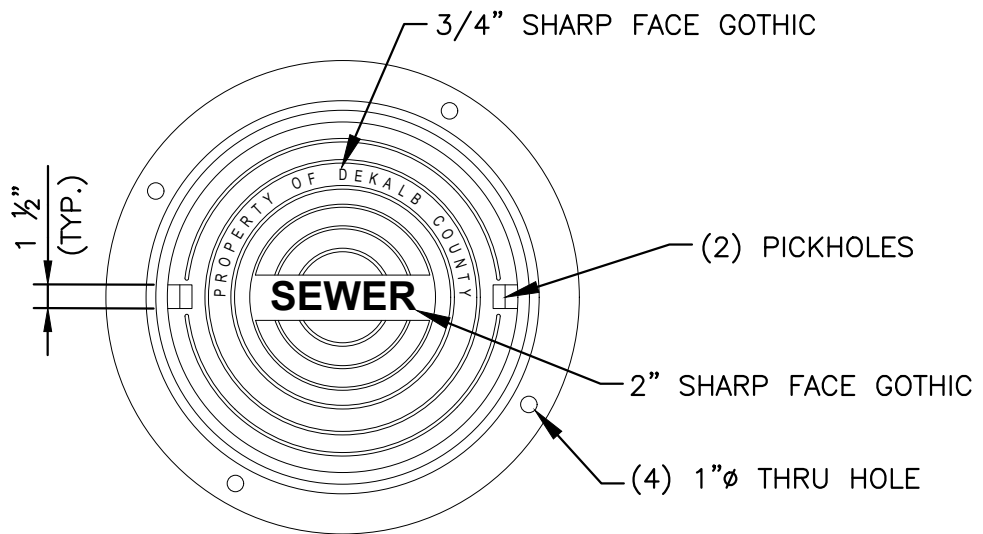

PLAN

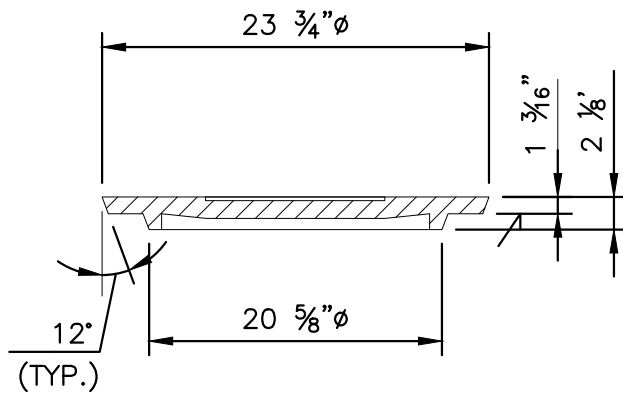

SECTION OF COVER

DESIGN FEATURES

- MATERIALS:
 FRAME: GRAY IRON (CL35B)
 COVER: GRAY IRON (CL35B)
- DESIGN LOAD
 HEAVY DUTY
- COATING: UNDIPPED
- ✓ DESIGNATES MACHINED SURFACE

CERTIFICATION

- ASTM A48
- COUNTRY OF ORIGIN: USA

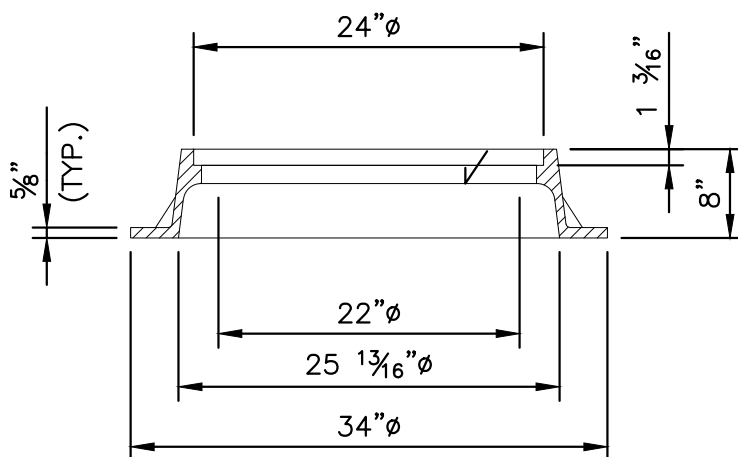

FRAME SECTION



STANDARD DETAILS

Traffic Manhole Frame and Cover

NOT TO SCALE

02/19



DETAIL NO. S-009

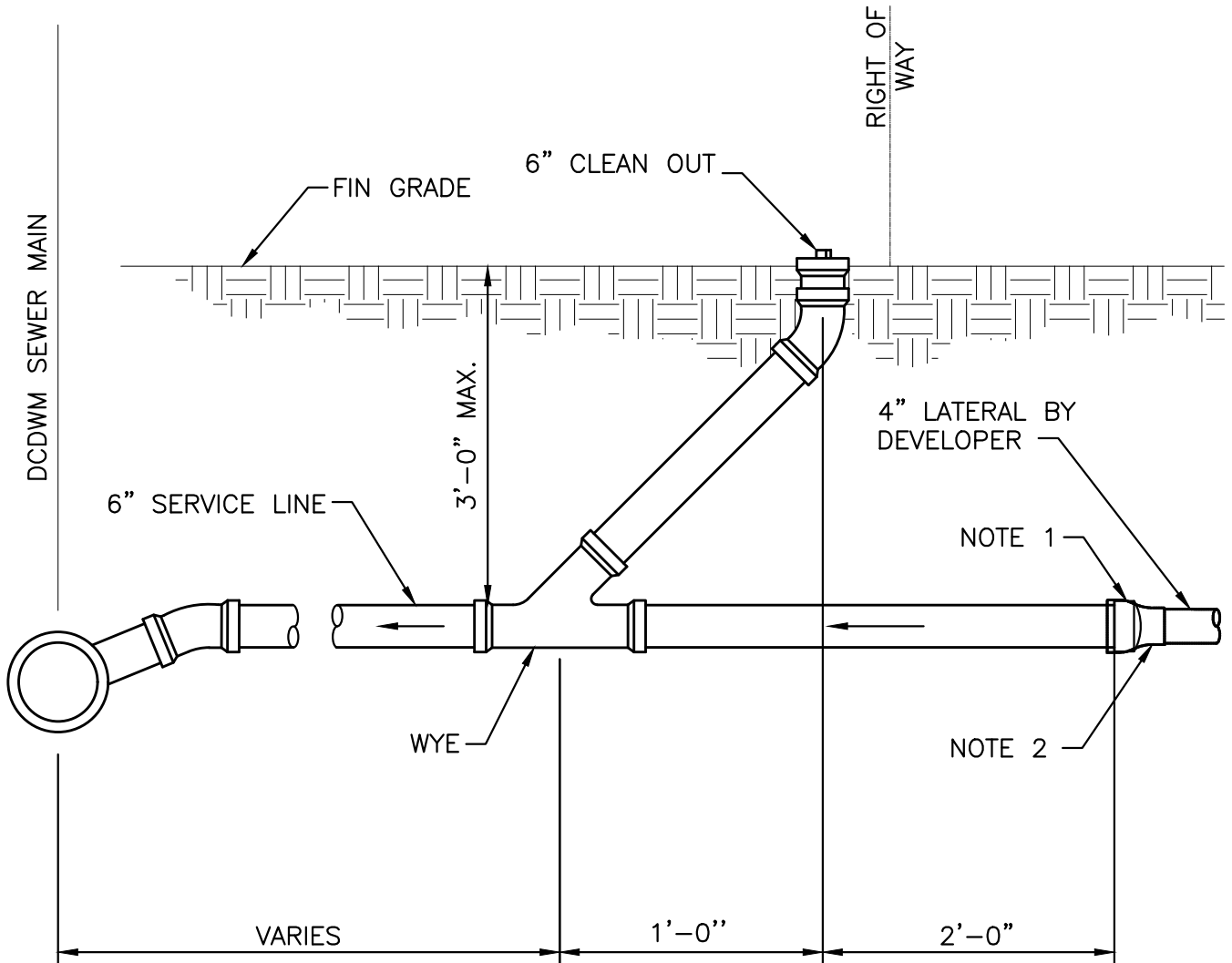

NOTES:

1. PLUG 6" SERVICE LINE.
2. CONNECT DEVELOPER'S 4" LATERAL TO 6" SERVICE LINE W/ 4" X 6" FERNCO COUPLING INCLUDING SST BANDS.
3. LATERALS UNDER PAVEMENT SHALL HAVE MINIMUM DEPTH OF FOUR (4) FEET.



STANDARD DETAILS

Typical Service Line and Clean Out Detail

NOT TO SCALE

02/19



DETAIL NO. S-012

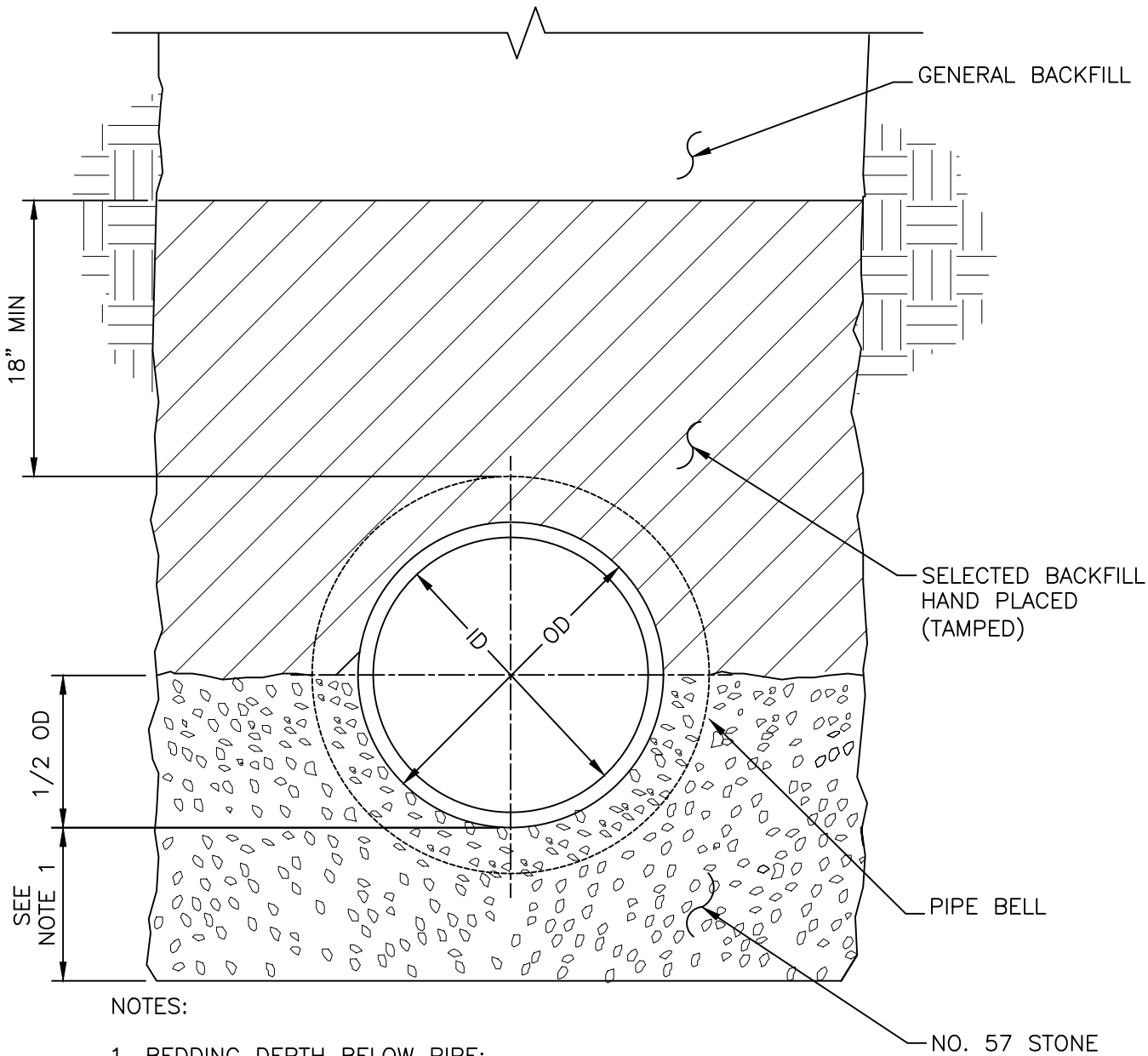

NOTES:

1. BEDDING DEPTH BELOW PIPE:



a.) PIPE DIAMETER UP TO 12”:

- i.) EQUAL TO 1/2 TIMES THE OUTSIDE DIAMETER (OD)
- ii.) MINIMUM 6”

b.) PIPE DIAMETER GREATER THAN 12”:

- i.) EQUAL TO 1/4 TIMES THE OUTSIDE DIAMETER (OD)
- ii.) MINIMUM 6”

c.) MAXIMUM 12”

 <p>DeKalb County GEORGIA</p>	STANDARD DETAILS	02/19
	<p>Class "B" Bedding</p> <p>NOT TO SCALE</p>	 <p>WATER Matters</p>
		DETAIL NO. S-014

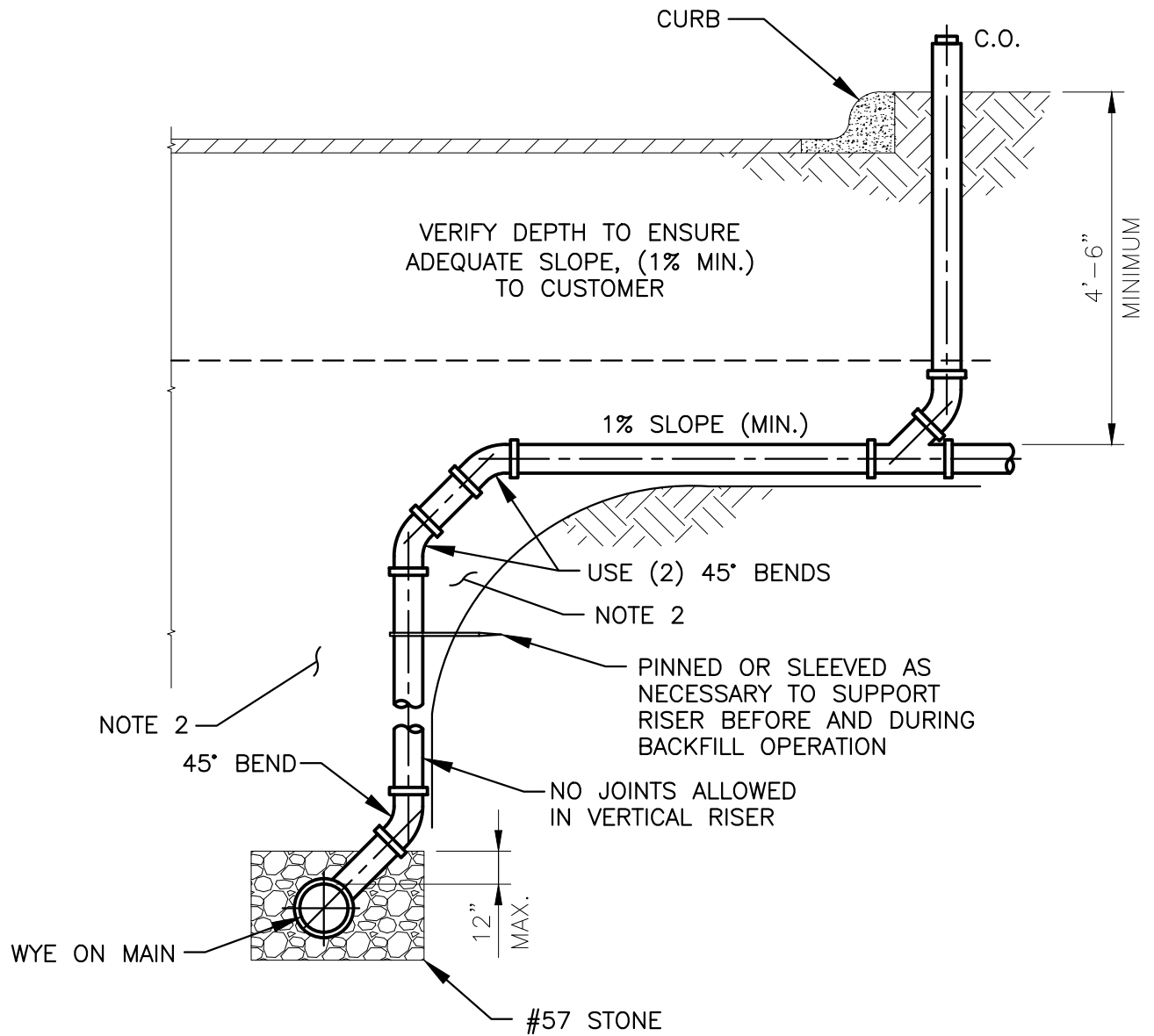

NOTES:

1. THIS DETAIL SHALL NOT BE USED WITHOUT WRITTEN PERMISSION FROM DCDWM.
2. CRUSHER RUN BACKFILL TAMPED IN 6" LAYERS TO NOT LESS THAN 95% STANDARD PROCTOR DENSITY BELOW ANY PAVED AREA.
3. ALL THE LATERAL CONNECTIONS INCLUDING THE WYE SHALL BE DIP.

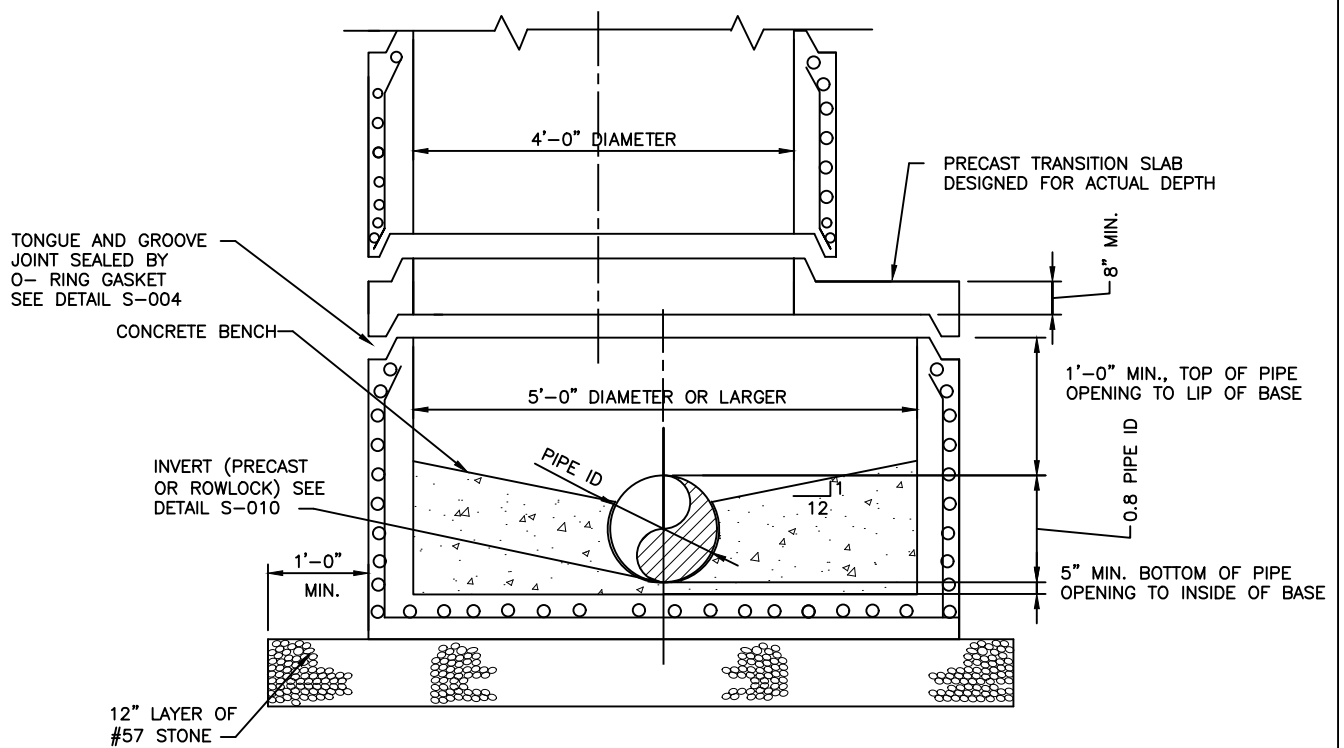

	STANDARD DETAILS	02/19
	Large Diameter Manhole Transition Base Detail	
NOT TO SCALE		DETAIL NO. S-025

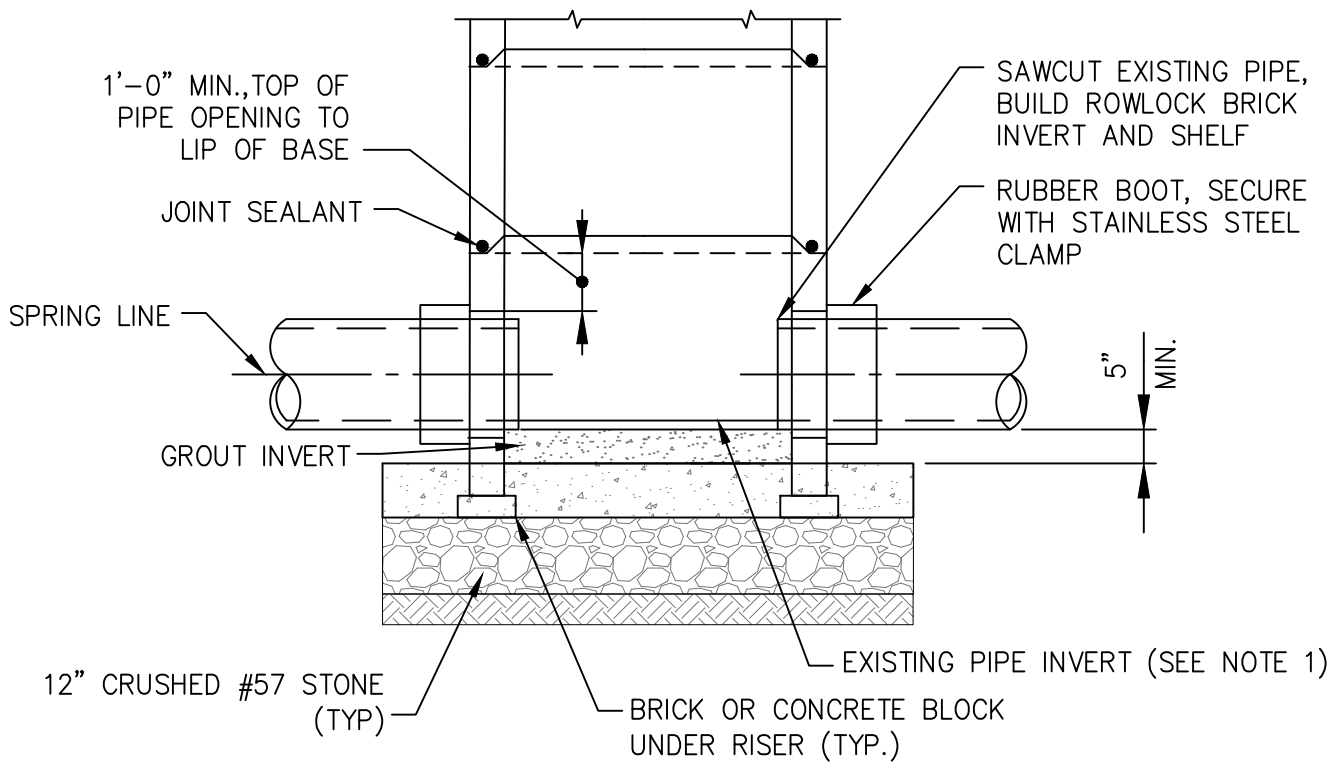
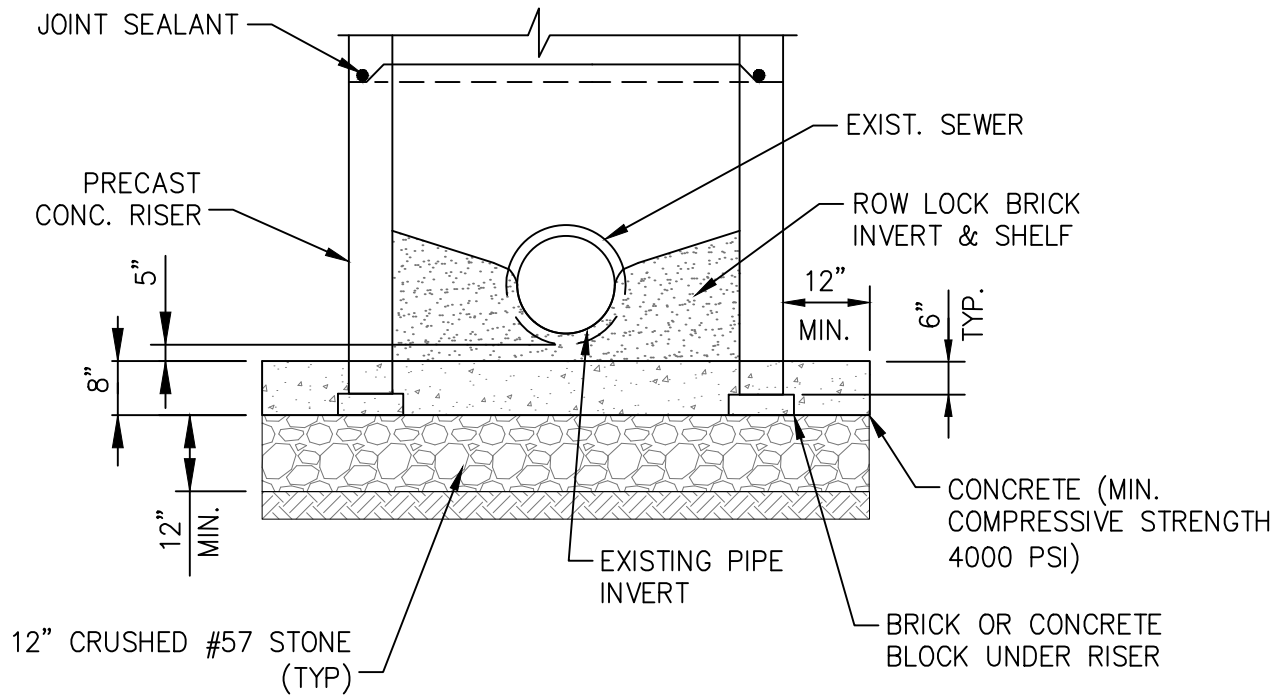

NOTE:

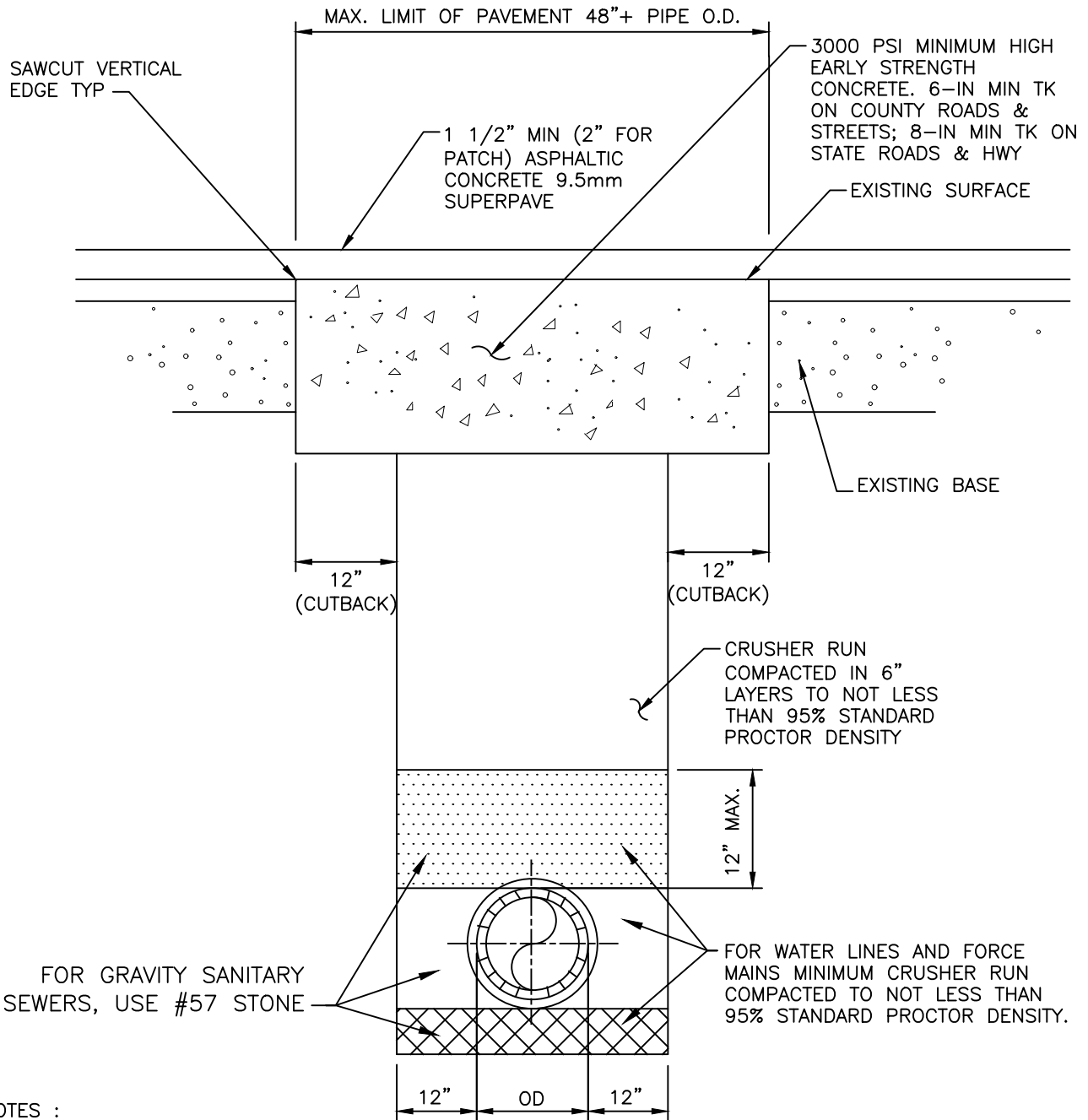

1. MAY USE THE EXISTING PIPE AS THE MANHOLE CHANNEL WITH DCDWM APPROVAL. SHALL BE SAWCUT AT SPRING LINE AND SHELF.

Appendix C: New General Construction Details



NOTES :

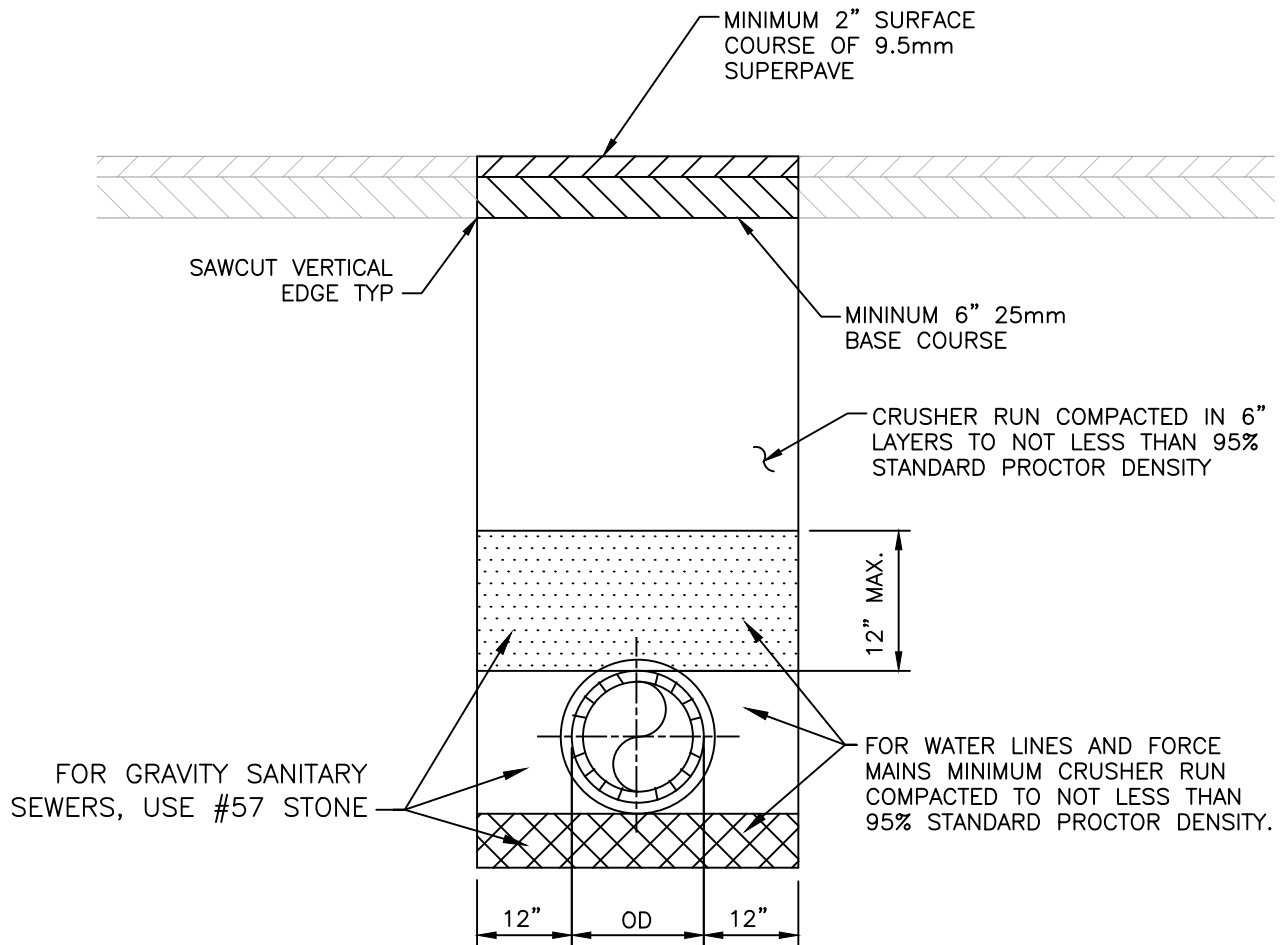

1. SAW CUT EXISTING PAVEMENT TO PROVIDE STRAIGHT VERT. JOINTS.
2. SURFACES TO BE CLEANED AND BITUMINOUS TACK COAT APPLIED BEFORE PLACEMENT OF ASPHALTIC TOP.
3. FOR EXIST SURFACE OF PORTLAND CEMENT CONCRETE, FURNISH NEW SURFACE OF 3000 PSI MINIMUM HIGH EARLY STRENGTH CONCRETE.
4. ON LONGITUDINAL CUTS EXCEEDING 100 FEET, THE CONC IN THE TRENCH SHALL BE BROUGHT FLUSH WITH THE EXISTING PAVEMENT AND THE ENTIRE WIDTH OF ROADWAY RESURFACED W/ 1-1/2 IN MIN THK OF ASPHALTIC CONC.

 <p>DeKalb County GEORGIA</p>	STANDARD DETAILS	02/19
	Typical Patch and Resurfacing Detail	
NOT TO SCALE		DETAIL NO. G-005



NOTES :

1. SAW CUT EXISTING PAVEMENT TO PROVIDE STRAIGHT VERT. JOINTS.
2. SURFACES TO BE CLEANED AND BITUMINOUS TACK COAT APPLIED BEFORE PLACEMENT OF ASPHALTIC TOP.
3. THIS DETAIL MAY ONLY BE USED WITH DCDWM'S APPROVAL.

 <p>DeKalb County GEORGIA</p>	STANDARD DETAILS	02/19
	Typical Asphalt Pavement Patch Without Concrete Cap	
	NOT TO SCALE	DETAIL NO. G-006

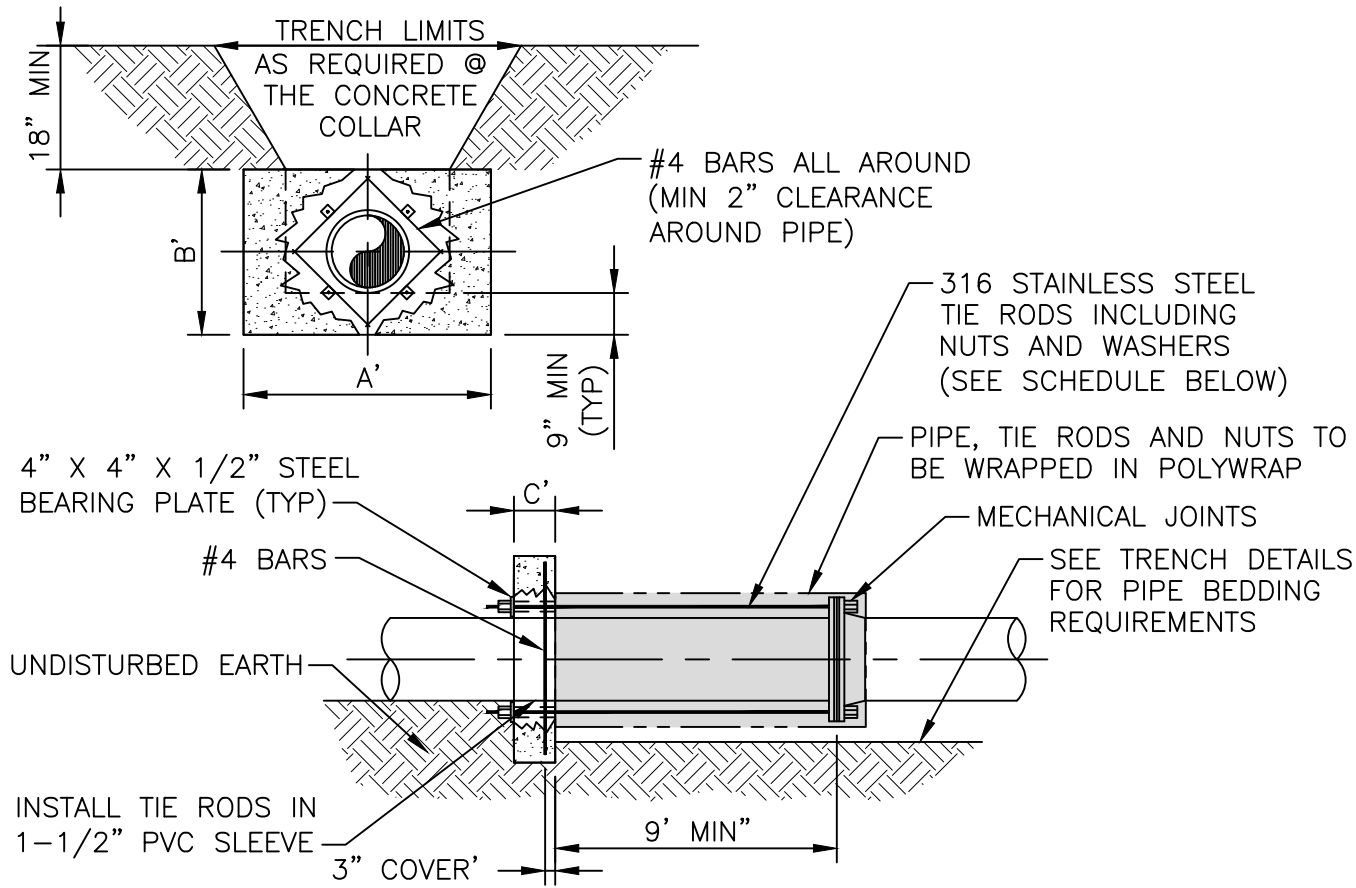

SCHEDULE OF DIMENSIONS AND MATERIALS					
PIPE SIZE (INCHES)	DIMENSIONS (FT.)			TIE RODS REQ'D	
	A	B	C	DIA. INCHES	NO.
6	2.0	2.0	1.0	3/4	2
8	2.5	2.5	1.0	3/4	2
10	3.5	3.0	1.0	3/4	2
12	5.0	3.0	1.0	3/4	2
16	6.0	4.0	1.5	3/4	4
20	8.0	5.0	1.5	3/4	6
24	9.0	6.0	1.5	3/4	8

NOTE: THRUST COLLAR AREAS TO BE COMPUTED ON BASIS OF 2000 LBS/SF SOIL RESTRAINT BEARING.

- NOTES:
1. ADDITIONAL REINFORCEMENTS SHALL BE AS SPECIFIED BY THE ENGINEER.
 2. MINIMUM COMPRESSIVE STRENGTH FOR CONCRETE SHALL BE 3000 PSI.
 3. BEDDING, BACKFILL AND COMPACTION SHALL BE AS SPECIFIED ELSEWHERE IN THE STANDARDS.
 4. ALL FORM BOARDS SHALL BE REMOVED PRIOR TO BACKFILL.
 5. NO ALLOWANCE SHALL BE MADE FOR FRICTION BETWEEN THE PIPE WALL AND THE THRUST COLLAR.
 6. DESIGN PRESSURE: 150 PSI.
 7. PIPE SIZE GREATER THAN 24" DIAMETER SHALL HAVE THRUST RESTRAINT DESIGNED BY A REGISTERED P.E.

	STANDARD DETAILS	02/19
	Thrust Restraint (150 psi) Tie-rod Installation Detail	
NOT TO SCALE		DETAIL NO. G-008

